

HAKKO 701

REPAIR SYSTEM

Repair System

Instruction Manual

•

Thank you for purchasing the HAKKO 701
Repair System.

Please read the manual before using the
HAKKO 701.

Store the manual in a safe, easily accessible
place for future reference.

•

 **CAUTION** : Remove the pump securing screw (M4×25 marked red)
from the bottom of the station.
Failure to do so may result in serious problems.

Table of Contents

Packing List	1
Precautions	2
Part Names (Station).....	3
(Soldering Iron/Desoldering Gun)...	4
Operation (Soldering).....	5-6
(Desoldering).....	7-12
Maintenance (Soldering Iron).....	13-14
(Desoldering Gun).....	15-18
(Station).....	19-20
Troubleshooting Guide	21-22
Parts List (Station).....	23-24
(Desoldering Gun).....	25
(Soldering Iron/Iron Holder).....	26
Specifications	26
Wiring Diagram	27

Packing List

Please check to make sure that all the items listed below are included in the HAKKO 701 package.

Station.....	1	Ceramic Paper Filter (S)	2
Soldering Iron.....	1	Ceramic Paper Filter (L)	4
Desoldering Gun.....	1	Spring Filter.....	3
Iron Holder for Soldering Iron.....	1	Cleaning Pin (for $\varnothing 1.0\text{mm}$ [0.04 in] nozzle).....	1
Iron Holder for Desoldering Gun.....	1	Cleaning Pin (for Heating Element).....	1
Filter Pipe.....	1	Cleaning Drill (for $\varnothing 1.0\text{mm}$ [0.04 in] nozzle).....	1
		Silicone Grease.....	1
		Spanner (for Desoldering Gun).....	1
		Instruction Manual.....	1

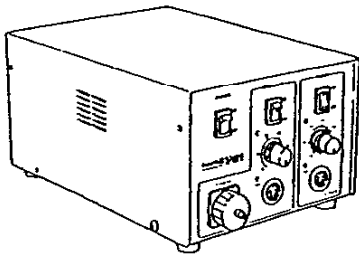

Station

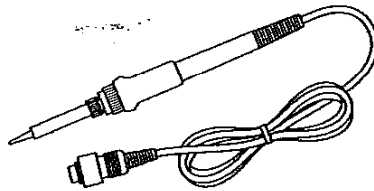

Soldering Iron

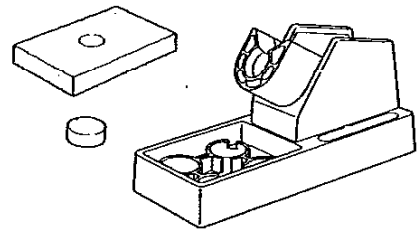

Iron Holder for Soldering Iron

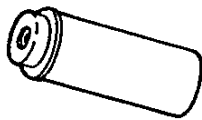

Filter Pipe

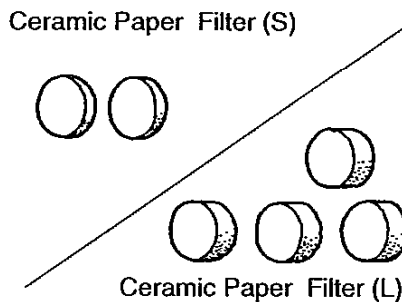

Ceramic Paper Filter (S)

Ceramic Paper Filter (L)

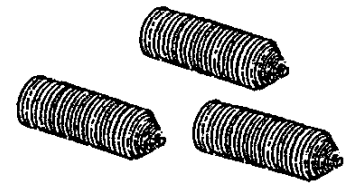

Spring Filter

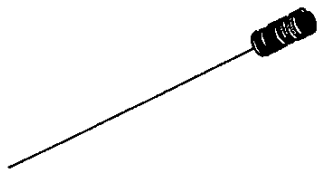

Cleaning Pin for $\varnothing 1.0\text{ mm}$ (0.04 in) Nozzle

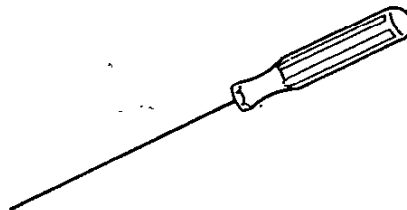

Cleaning Pin for Heating Element



Cleaning Drill for $\varnothing 1.0\text{ mm}$ (0.04 in) Nozzle

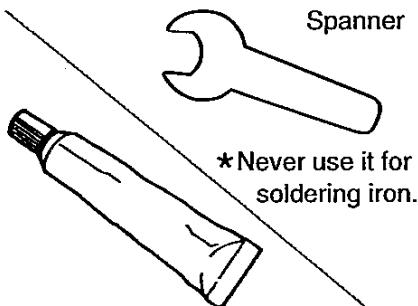

Spanner

*Never use it for soldering iron.

Silicone Grease

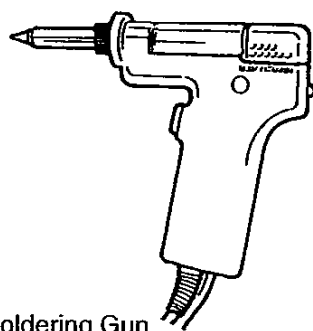

Desoldering Gun

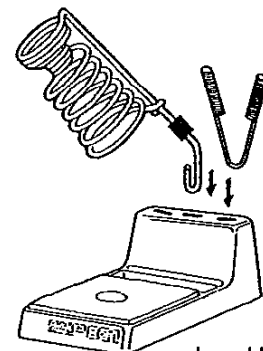



Iron Holder for Desoldering Gun

Precautions

In this instruction manual, "WARNING" and "CAUTION" are defined as follows.

WARNING

 **WARNING:** Misuse may potentially cause death of, or serious injury to the user.

 **CAUTION :** Misuse may potentially cause injury to the user or physical damage to the objects involved.

For your own safety, be sure to comply with these precautions.

CAUTION

Remove the pump securing screw (M4×25 marked red) from the bottom of the station.

Failure to do so may result in serious problems.

When the power is on, the tip and the nozzle temperature is between 200°C/392°F and 480°C/896°F.

Since mishandling may lead to burns or fire, be sure to comply with the following precautions.

- Do not touch the metallic parts near the tip and the nozzle, nearby plastic parts and the spring iron holder .
- Do not use the product near flammable items.
- Advise other people in the work area that the unit can reach a very high temperature and should be considered potentially dangerous.
- Turn the power off while taking breaks and when finished using the unit.
- Before replacing parts or storing the unit, turn the power off and allow the unit to cool to room temperature.

To prevent damage to the unit and ensure a safe working environment, be sure to comply with the following precautions.

- Do not use the unit for applications other than soldering or desoldering.
- Do not rap the desoldering gun against the work bench to shake off residual solder, or otherwise subject the iron or the gun to severe shocks.
- Do not modify the unit.
- Use only genuine HAKKO replacement parts.
- Do not wet the unit or use the unit when your hands are wet.
- Set the ceramic paper filter (S) for the filter retainer (station), and the ceramic paper filter (L) for the filter pipe (gun).
- Maintain the soldering iron or the desoldering gun and the station.
- While using the unit, don't do anything which may cause bodily harm or physical damage.

● Soldering Iron (HAKKO 907 ESD)

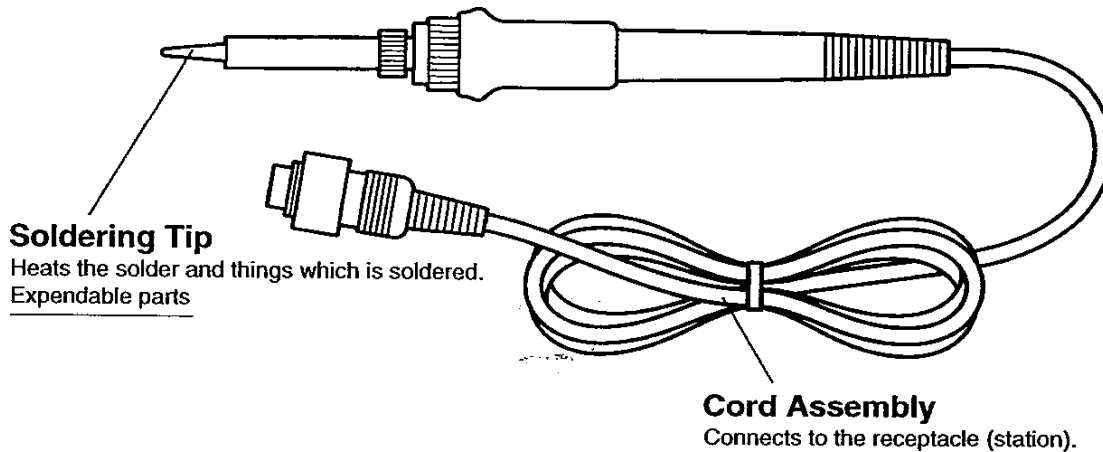

● Desoldering Gun (HAKKO 809)

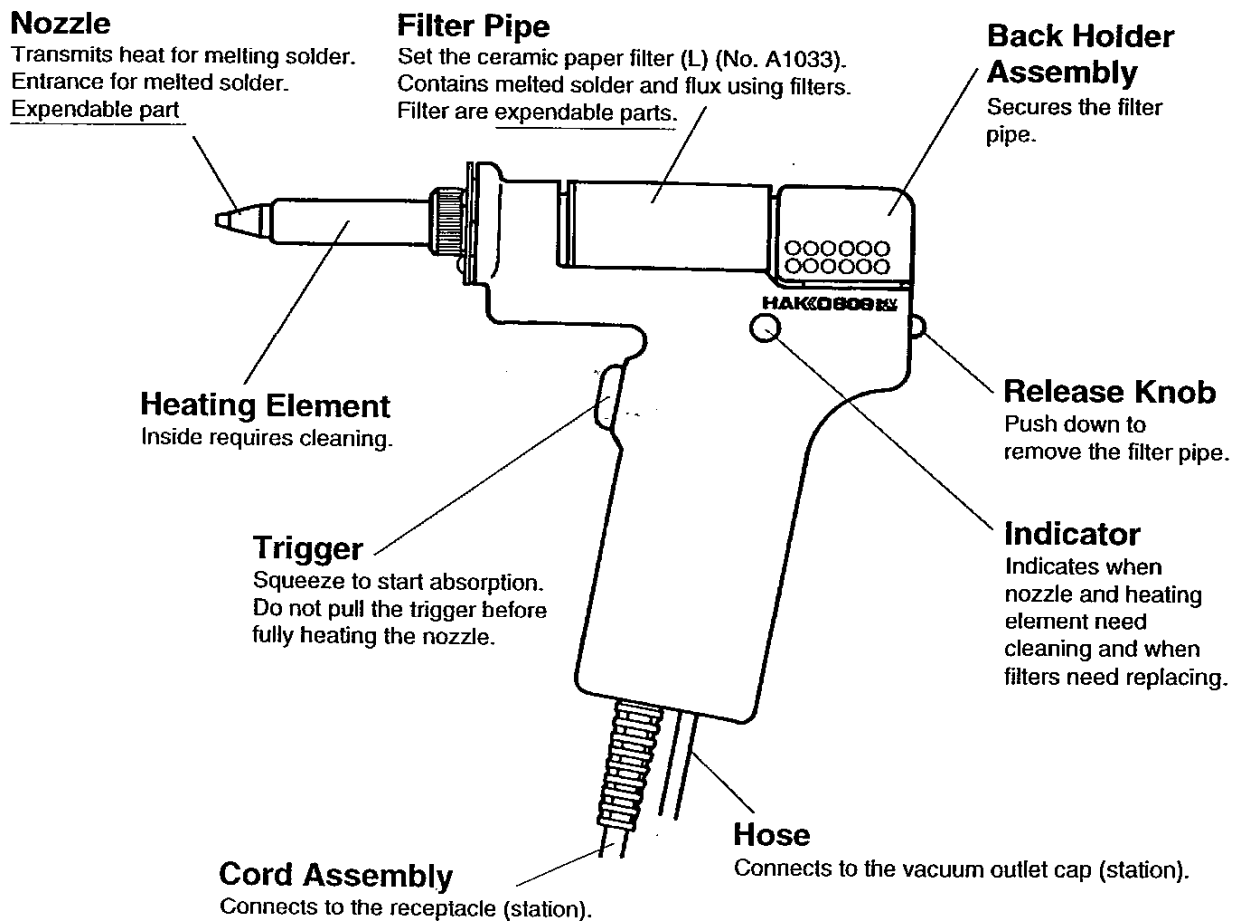

Operation (Soldering)

⚠ CAUTION : The sponge is compressed. It will swell when moistened with water. Before using the unit, dampen the sponge with the water and squeeze it dry. Failure to do so may result in damage to the soldering tip.

① Assemble the iron holder for soldering iron.

1. Small Cleaning Sponge
Dampen the small cleaning sponge with water and then squeeze it dry. Place it in one of the 4 openings of the iron holder base.
2. Add water to approximately the level as shown.
The small sponge will absorb water to keep the larger sponge above it wet at all times.
3. Dampen the large cleaning sponge and place it on the iron holder base.
* The large sponge may be used alone (w/o small sponge & water).

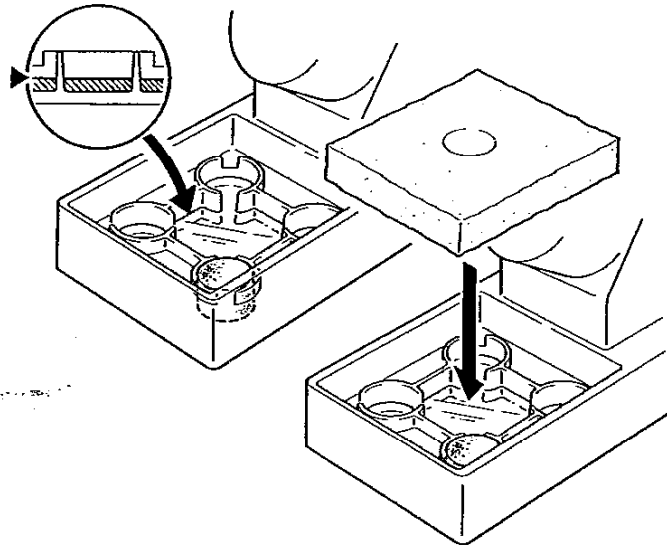

⚠ CAUTION : Be sure to turn off the switch before connecting or disconnecting the soldering iron. Failure to do so may damage the P.W.B.

② Connections

1. Place the soldering iron in the iron holder.
2. Connect the cord assembly of soldering iron (HAKKO 907-ESD) to the receptacle of soldering iron (marked "solder").
3. Plug the power cord into the power supply.

⚠ CAUTION

- Be sure to turn off the power switch before connecting the plug.
- The entire unit is constructed of conductive materials. Always ground the unit.

③ Set the temperature.

Set the temperature control knob to the desired temperature.

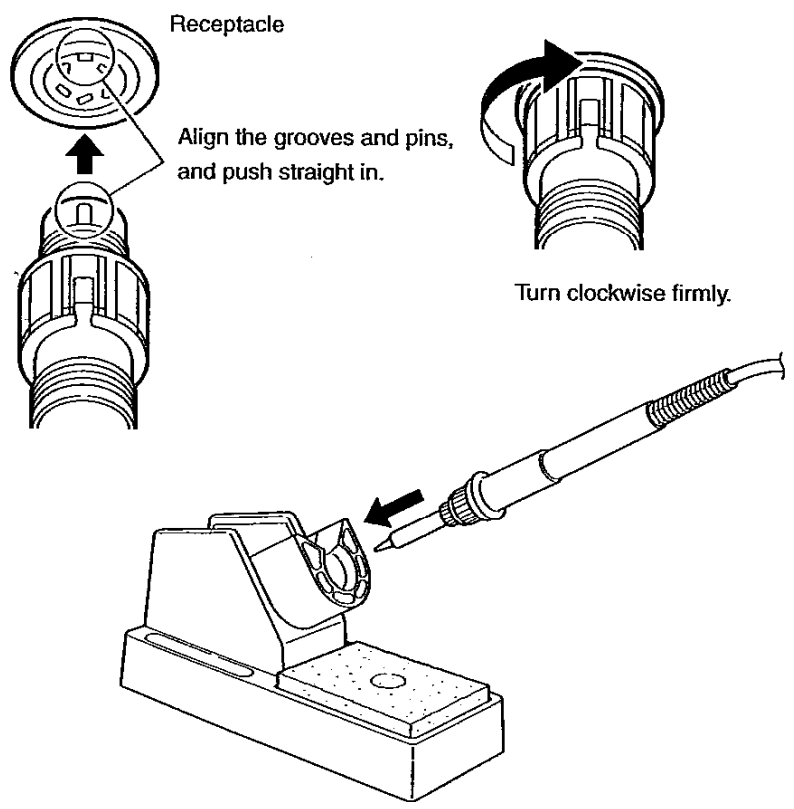

④ Turn on the power switch.

1. Turn the power switch to ON. The switch should light up.
2. Turn the switch for soldering iron to ON. The L.E.D. heater lamp should light up.
3. The L.E.D. heater lamp blinks on and off when the tip temperature reaches the set temperature. The unit is now ready to perform soldering work.

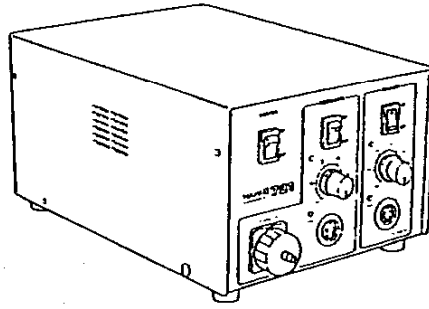

⚠ CAUTION : The soldering iron must be placed in the iron holder when not in use.

Tip Care and Use

•Tip Temperature

High soldering temperatures can degrade the tip. Use the lowest possible soldering temperature. The excellent thermal recovery characteristics ensure efficient and effective soldering even at low temperatures. This also protects the soldered items from thermal damage.

•Cleaning

Clean the tip regularly with a cleaning sponge, as oxides and carbides from the solder and flux can form impurities on the tip. These impurities can result in defective joints or reduce the tip's heat conductivity. When using the soldering iron continuously, be sure to loosen the tip and remove all oxides at least once a week. This helps prevent seizure and reduction of the tip temperature.

•When not in use

Never leave the soldering iron sitting at high temperature for long periods of time, as the tip's solder plating will become covered with oxide, which can greatly reduce the tip's heat conductivity.

•After use

Wipe the tip clean and coat the tip with fresh solder. This helps prevent tip oxidation.

Operation (Desoldering)

Preparation—Assembly and Connection

Assemble the iron holder on a flat surface.

- 1 Remove the pump securing screw (M 4×25 marked red) from the bottom of the station.

2 Assemble the iron holder.

1. Set the spring iron holder and cleaning pin holder in the iron holder base.
2. Dampen the cleaning sponge with water and then squeeze it dry.

CAUTION

- The sponge is compressed. It will swell when moistened with water. Be sure to dampen the sponge with water before use.
- Be sure to remove the round portion of the sponge.

3 Insert the desoldering gun and cleaning pins.

Fully insert the desoldering gun into the spring iron holder.

CAUTION

The spring iron holder becomes extremely hot during operation of the desoldering gun. Do not touch the spring iron holder during and immediately after using the gun.

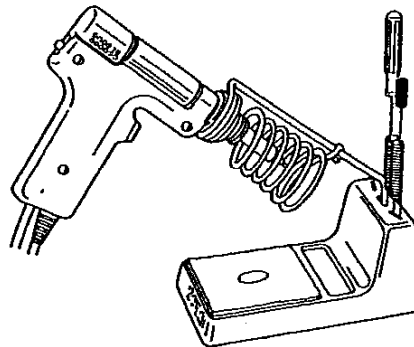
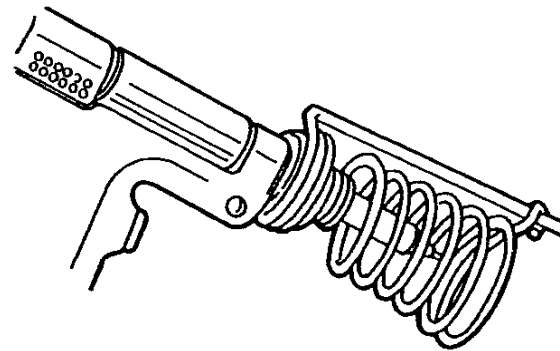
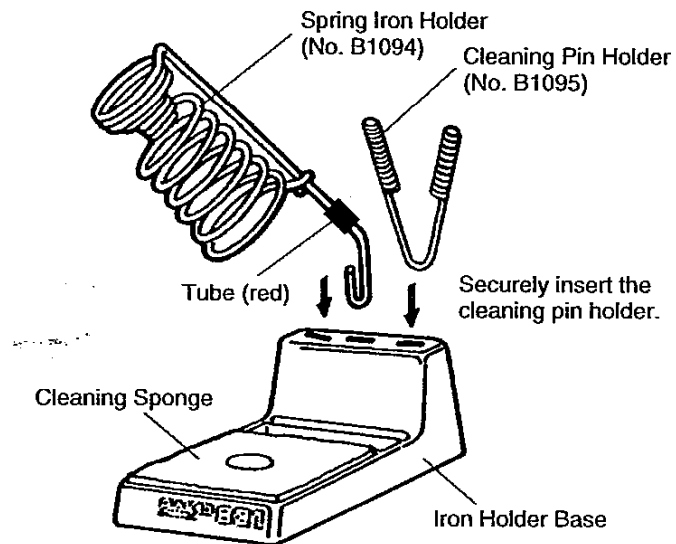

④ Connections

⚠ CAUTION

Be sure to turn off the power switch before connecting or disconnecting the cord assembly and the power plug. Failure to do so may damage the P.W.B.

1. Connect the cord assembly of the desoldering gun (HAKKO 809) to the receptacle of the desolder (marked "DESOLDER").
2. Connect the hose to the vacuum outlet cap (marked "VACUUM").
3. Plug the power cord into the power supply.

⚠ CAUTION

- Confirm that the power switch is set in the OFF position, then connect the power plug to the power source.
- The entire unit is constructed of conductive materials. Always ground the unit.

⑤ Power switch

1. Turn the power switch to ON. The power lamp should light up.
2. Turn the switch for desolder to ON. The nozzle begins to heat up as soon as the switch is turned to ON.

- ⑥ After turning the switch to ON, wait 3 minutes before beginning desoldering operations.

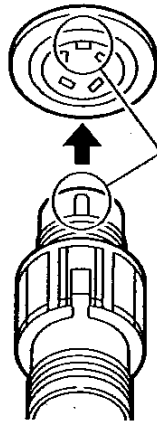

Insert the cord assembly by keying the plug to the key on the receptacle.

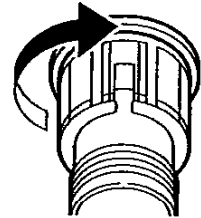

Secure the plug by turning it clockwise.

VACUUM

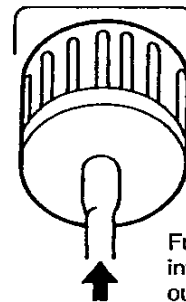

Fully insert the hose into the vacuum outlet cap.



The power lamp lights up.

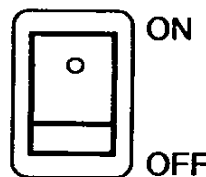

The nozzle heats up.

⚠ CAUTION The desoldering gun must be placed in the iron holder when not in use.

Operation (Desoldering)

Desoldering

After turning the switch to ON, wait 3 minutes before beginning desoldering operations.

① Set the temperature.

⚠ CAUTION

Always set the temperature to as low as possible for the work being done.

To more precisely set the temperature, measure the temperature at the nozzle using a soldering iron thermometer and adjust the temperature control knob accordingly.

We recommend the HAKKO 191 thermometer or HAKKO 192 soldering tester for measuring the nozzle temperature.

② Clean the tip of the nozzle.

Keep the solder-plated section of the nozzle a shiny white by coating it with a small amount of solder.

If the tip of the nozzle is coated with oxide, the nozzle's heat conductivity will be lowered. Coating the tip with a small amount of fresh solder ensures maximum heat conductivity.

The temperature can be adjusted between 380°C (716°F) and 480°C (896°F) with temperature control knob.

Please refer to the chart below, and adjust the temperature control knob.

knob	P.W.B.
1 ~ 2	Single-sided P.W.B.
3 ~ 4	Through-hole P.W.B.
5 ~ 6	Multilayer P.W.B.

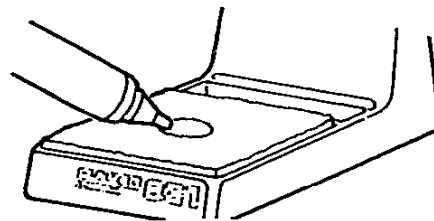

Wipe away any oxide or old solder from the nozzle using the hole in the center of the sponge.

③ Melt the solder.

1. Apply the nozzle to the soldered part and melt the solder.

⚠ CAUTION

Never allow the nozzle to touch the board itself.

2. Confirm that the solder is melted.

⚠ CAUTION

To confirm that all the solder is melted, observe the inside of the hole and the backside of the P.W.B. If this is difficult to do, try slowly moving the lead with the nozzle—if the lead moves, the solder is melted.

⚠ CAUTION

Never move the lead by force. If it doesn't move easily, the solder isn't yet fully melted.

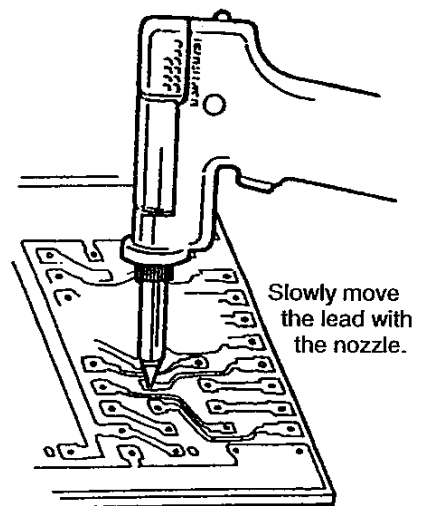
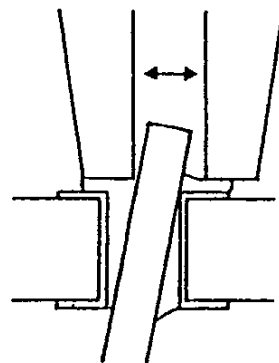
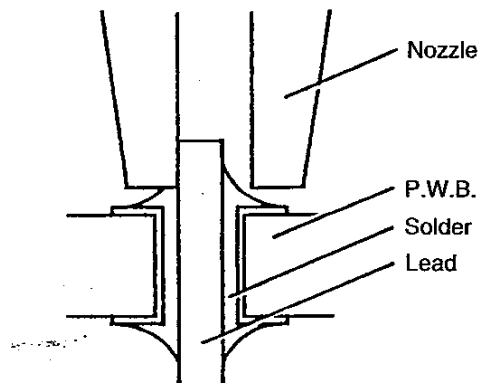

④ Absorb the solder.

1. After confirming that the solder is completely melted, absorb the solder by squeezing the trigger on the gun.

⚠ CAUTION

Never leave any solder remaining inside the hole in the P.W.B.

2. After fully absorbing all the solder, cool the soldering junction in order to prevent it from becoming resoldered.

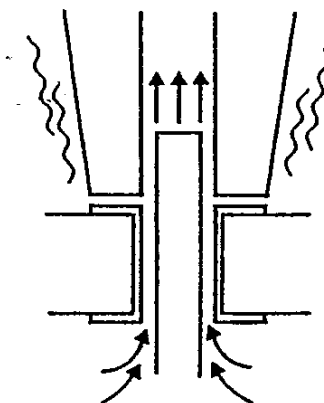

Absorb the solder by slowly moving the lead back and forth with the tip of the nozzle.

⑤ Problems during desoldering

If solder remains, resolder the component and repeat the desoldering process.

Operation (Desoldering)

Heated solder and flux can cause oxides to form and adhere to the nozzle and the inside of the heating element. These oxides not only lower the heat conductivity, but can also clog the nozzle and heating element, resulting in a drop in suction efficiency. Should there be a noticeable drop in suction efficiency during operation, replace the filter and clean the nozzle and heating element with the provided cleaning pin.



Cleaning during Operation

① Observing the indicator

While looking at the indicator and with the hole of the nozzle open, pull the trigger and look at the indicator. If it is red, clean the nozzle and heating element, empty the filter pipe, and replace the filters. If the indicator is blue, cleaning is not necessary and operations can be resumed.

⚠ CAUTION

The indicator will not operate accurately if the hole of the nozzle is closed or if the solder in the hole of the P.W.B. is not melted.

Normal	Abnormal	Solution
		If the indicator is more than half red, replace the filter and clean the nozzle and the inside of the heating element. (refer to p.15 Maintenance of the Desoldering Gun)
Blue or slight amount of red can be seen.	More than half of the indicator is red.	

⚠ CAUTION : If there is a noticeable drop in suction efficiency, clean the nozzle and heating element with the cleaning pin.

② Replacing the filter

Replace the filter as shown ①~③. During operation, the filter pipe is very hot. Wait until the filter pipe is cool before replacing the filter. We recommend keeping a second filter pipe containing new filters handy, and replacing the installed filter pipe with this backup filter pipe.

③ Replace the entire filter pipe with the provided backup filter pipe.

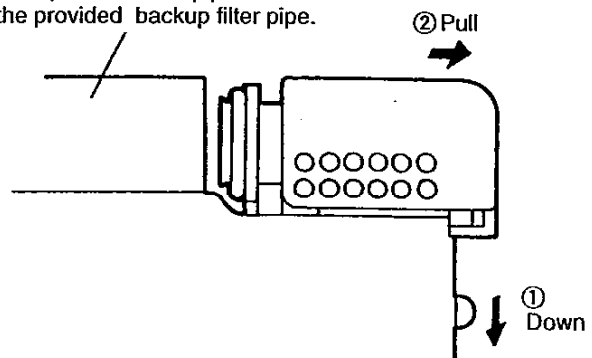

Problems during Desoldering

- A. The solder in the junction is not sufficiently melted.
- B. Suction power is dropping.

A. The solder in the junction is not sufficiently melted.

● Temperature is not high enough.

The following parts require a greater heat capacity to desolder.

- Multilayer P.W.B.s, power supplies, ground planes in through-hole P.W.B.s, high-capacity transistors, triacs with heat radiation fins, tuner P.W.B. ground wires, and large-scale transformer terminals.

Use a preheating oven or heating gun to heat the P.W.B. to a temperature that won't damage the board or its components [between 70°C (160°F) and 80°C (180°F)], then desolder. Do not increase the temperature of the gun by recalibration as this may damage the P.W.B. and its components.

● Nozzle is worn out.

- When the nozzle begins to wear out, the heating efficiency begins to decline. Check the nozzle. If the solder plating is damaged, or the nozzle is eroded, replace the nozzle. (refer to p.15)

B. Suction power is dropping.

- Replace the filters, and clean the nozzle and the inside of the heating element. (refer to p.15~20, Maintenance of the Desoldering Gun and Station)

● Air is leaking from the vacuum system.

Air leakage cannot be determined from the indicator. Check the air-tightness of the following parts and replace any that are worn.

- | | |
|--|------------------------------|
| a. Contact point of the nozzle and heating element | c. O-ring in the back holder |
| b. Front holder and nearby parts | d. Hose |
| | e. Vacuum outlet cap |
| | f. Packing and nearby parts |

Post-operation Maintenance

To ensure a long service life, always perform the following maintenance procedures immediately after using the HAKKO 701 unit.

- Remove all solder from the inside of the nozzle and heating element.
- Clean the tip of the nozzle with the cleaning sponge, then coat the tip with a fresh layer of solder to protect the solder plating.

Maintenance (Soldering Iron)

Inspect and Clean the Tip

CAUTION : Never file the tip to remove oxide.

1. Set the temperature to 250°C (482°F).
2. When the temperature stabilizes, clean the tip with the cleaning sponge and check the condition of the tip.
3. If there is black oxide on the solder-plated portion of the tip, apply new solder (containing flux) and wipe the tip on the cleaning sponge. Repeat until the oxide is completely removed. Coat with new solder.
4. If the tip is deformed or heavily eroded, replace it with a new one.

Calibrating the Iron Temperature

The soldering iron should be recalibrated after changing the iron, or replacing the heating element or tip.

1. Connect the cord assembly plug to the receptacle on the station.
2. Set the temperature control knob to 400°C (750°F).
3. Turn the power switch to 'ON' and wait until the temperature stabilizes.
4. When the temperature stabilizes, use a regular or small cross point screwdriver to adjust the screw (marked CAL at the station) until the tip thermometer indicates a temperature of 400°C (750°F). Turn the screw clockwise to increase the temperature and counterclockwise to reduce the temperature.

* We recommend the HAKKO191/192 thermometer for measuring the tip temperature.

Tips

The tip temperature will vary according to the shape of the tip. The preferred method of adjustment uses a tip thermometer.

A less accurate method involves adjusting the temperature control knob according to the adjustment value for each tip.

Example : When using a 900M-T-H tip at 400°C (750°F), the difference between this tip and a 900M-T-B is -20°C (-36°F). Set the temperature control knob to 420°C (786°F).

Refer to the chart for the correct adjustment values.

CAUTION : Use only genuine HAKKO 907 replacement parts. Never use tips for HAKKO DASH.

907

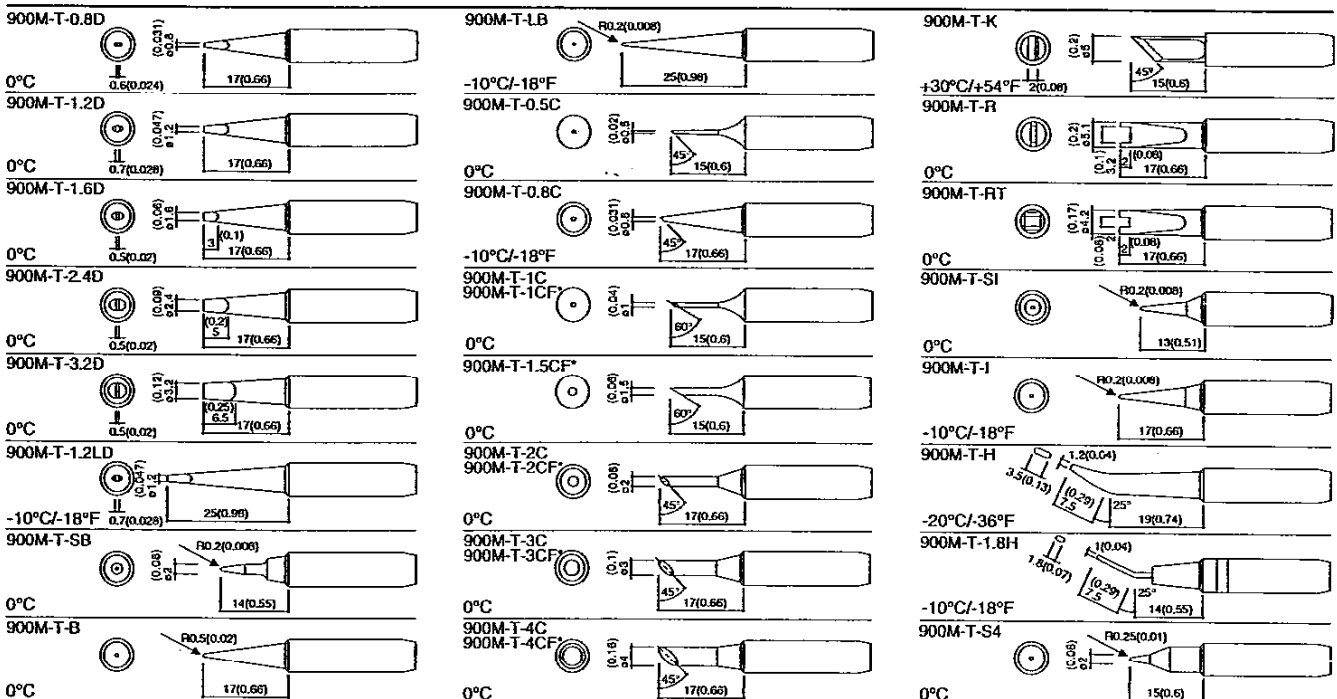

*900M tip Out Diam ø6.5

Checking for Breakage of the Heating Element, Cord Assembly and Tip to Ground Resistance

Disconnect the plug and measure the resistance value between the connecting plug pins as follows.

If the values of 'a' and 'b' are outside the above value, replace the heating element (sensor) and/or cord assembly. Refer to procedures 1 and 2.

a	Between pins 4&5 (Heating Element)	2.5 - 3.5Ω (Normal)
b	Between pins 1&2 (Sensor)	43 - 58Ω (Normal)
c	Between pin 3&Tip	Under 2Ω

Broken Heating Element

Disassembling the 907

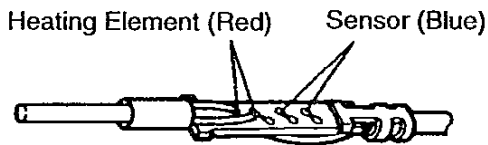
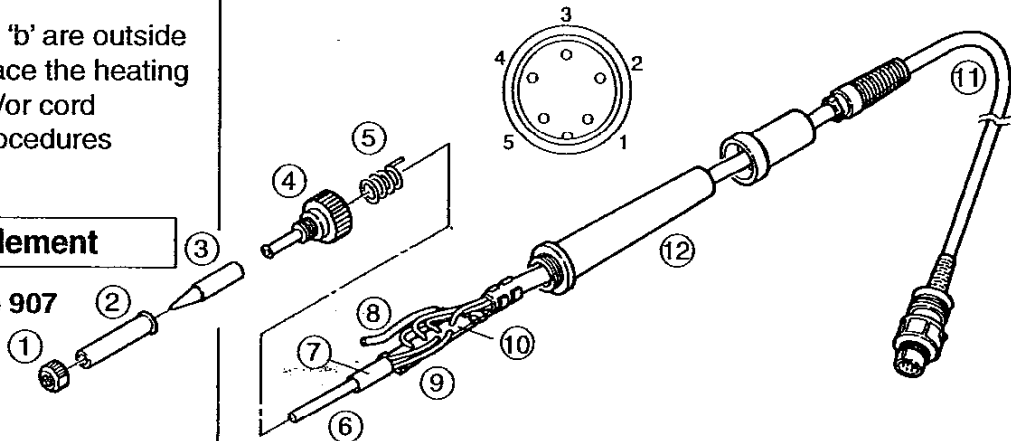

1. Turn the nut (1) counterclockwise and remove the tip enclosure (2), the tip (3).
2. Turn the nipple (4) counterclockwise and remove it from the iron.
3. Pull both the heating element (6) and the cord assembly (11) out of the handle (12). (Toward the tip of the iron.)
4. Pull the grounding spring (5) out of the D-sleeve.

Measure when the heating element is at room temperature.

1. Resistance value of heating element (RED) 2.5 - 3.5Ω
2. Resistance value of sensor (BLUE) 43 - 58Ω

If the resistance value is not normal, replace the heating element. (Refer to the instructions included with the replacement part.)

After replacing the heating element,

1. Measure the resistance value between 1) pins 4 & 1 or 2 2) pins 5 & 1 or 2. If it is not ∞, the heating element and sensor are touching. This will damage the P.W.B.
2. Measure the resistance value 'a', 'b', and 'c' to confirm that the leads are not twisted and that the grounding spring is properly connected.

Broken Soldering Iron Cord

There are two methods of testing the soldering iron cord.

CAUTION

The LED heater lamp will flicker even with a normal iron cord if the temperature reaches 480°C (896°F).

Checking the Tip to Ground Resistance

If the value of 'c' is over the above value, remove the oxidization film by lightly rubbing with sand-paper or steel wool the points shown below.

1. Turn the unit ON and set the temperature control knob to 480°C (896°F). Then wiggle and kink the iron cord at various locations along its length, including in the strain relief area.

If the LED heater lamp flickers, then the cord needs to be replaced.

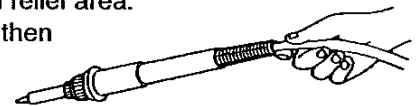

2. Check the resistance between the pin of the plug and the wire on the terminal.

Pin 1: Red pin 2: Blue pin 3: Green pin 4: White pin 5: Black
The value should be 0Ω. If it is greater than 0Ω or is ∞, the cord should be replaced.



Maintenance (Desoldering Gun)

Properly maintained, the HAKKO 809 desoldering gun should provide years of good service. Efficient desoldering depends upon the temperature, and the quality and quantity of the solder and flux. Perform the following service procedures as dictated by the conditions of the gun's usage.

⚠WARNING : Since the desoldering gun can reach a very high temperature, please work carefully. Except when cleaning the nozzle and heating element, always turn the power switch off and disconnect the power plug before performing any maintenance procedure.

Servicing the Desoldering Gun

⚠CAUTION

The desoldering gun will be extremely hot. During maintenance, please wear gloves and work carefully.

① Inspect and clean the nozzle.

1. Plug in the power cord, turn the power switch On and let the nozzle heat up.
2. Clean out the hole of the nozzle with the nozzle cleaning pin.

⚠CAUTION

The cleaning pin will not pass through the nozzle until the solder inside the nozzle is completely melted.

If the cleaning pin does not pass through the hole in the nozzle, clean with the cleaning drill.

3. Check the condition of the solder plating on the tip of the nozzle. If it is slightly worn, recoat the tip with fresh solder to prevent oxidation.
4. Check the condition of the surface and inside hole of the nozzle. If either is worn or eroded, or the inside diameter seems unusually wide, replace the nozzle.

⚠CAUTION

The inside hole and the surface of the nozzle is plated with a special alloy. Should this alloy become eroded by high-temperature solder, the nozzle will not be able to maintain the proper temperature.

Cleaning with the nozzle cleaning pin

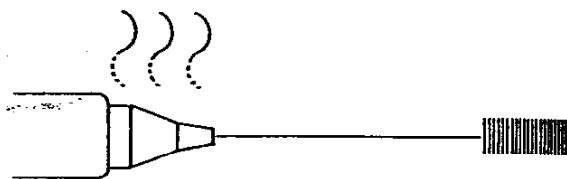

The cleaning pin passes completely through the hole.

Cleaning with the cleaning drill

• Before cleaning

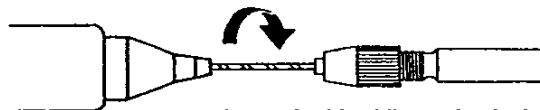

Insert the bit while turning it clockwise.

• After cleaning

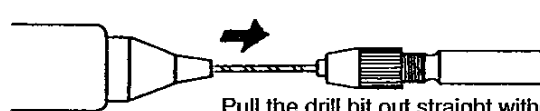

Pull the drill bit out straight without turning it.

⚠CAUTION

If the cleaning drill is forced into the nozzle, the drill bit could break or be damaged.

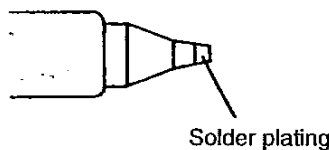

⚠CAUTION

Please use the proper sized cleaning pin or cleaning drill for the nozzle diameter.

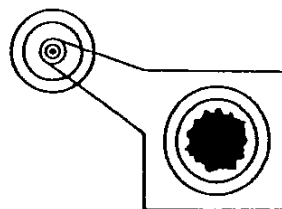

Diameter of hole is widened through erosion.

⚠CAUTION

Unfortunately, it is often difficult to observe this condition. Therefore, if desoldering efficiency goes down and all other parts appear to be OK, the nozzle is probably eroded and should be replaced.

② Disassemble the heating element.

⚠ CAUTION

The heating element is very hot during operation.

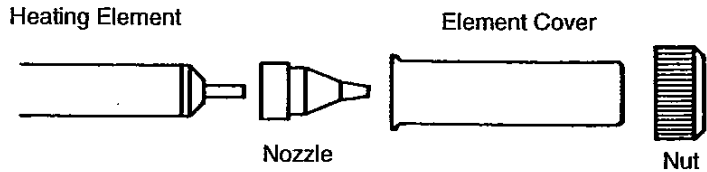

Remove the nut with the attached spanner.

③ Clean out the hole in the heating element with the provided cleaning pin.

⚠ CAUTION

Be sure the solder in the hole in the heating element is completely heated, before cleaning the hole.

Scrape away all oxidation from the hole in the heating element until the cleaning pin passes cleanly through the hole.

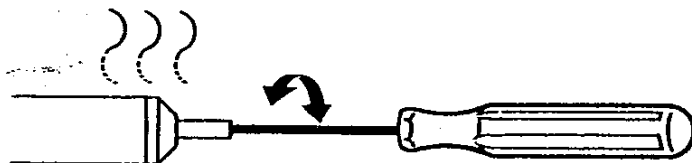

The cleaning pin passes cleanly and completely through the hole.

1. If the cleaning pin cannot pass through the hole, replace the heating element.
2. Turn the power off after cleaning.

④ Replace the filters.

1. When the filter pipe is cool to the touch, push down the release knob at the back of the gun and remove the filter pipe.

⚠ CAUTION

The filter pipe is very hot.

Front Holder



Spring Filter



Ceramic Paper Filter (L)
(No. A1033)

2. Examine the front holder.
3. Examine the spring filter.
4. Examine the ceramic paper filter (L). **(No. A1033)**

Replace
Stiff and cracked.

Replace
Solder is collected in two-thirds of the spring filter.

Replace
Ceramic paper filter is stiff with flux and solder.

⑤ Secure the filters.

1. Attach the spring filter to the front holder.
2. Attach the front holder to the filter pipe.

⚠ CAUTION

Be sure the front holder is correctly aligned.

⚠ CAUTION

Use the ceramic paper filter (L) for the filter pipe (gun). Using of the ceramic paper filter (S) in the filter pipe may cause to break or the power to drop.

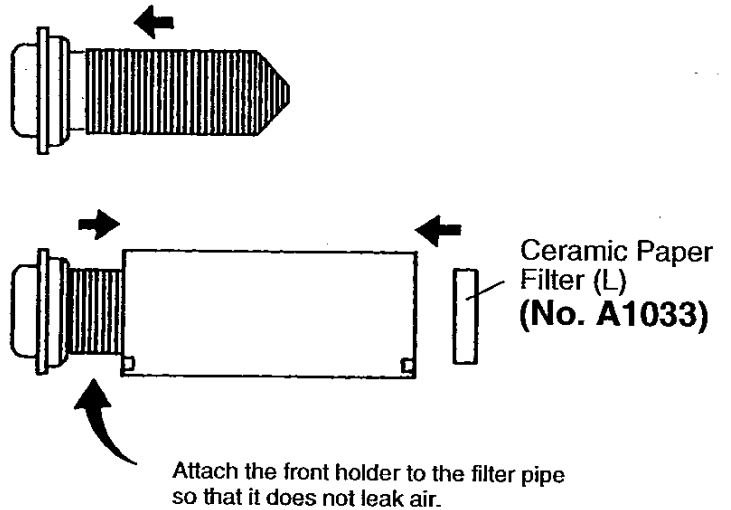

Firmly press the back holder assembly into the filter pipe in order to properly seat the O-ring against the pipe.

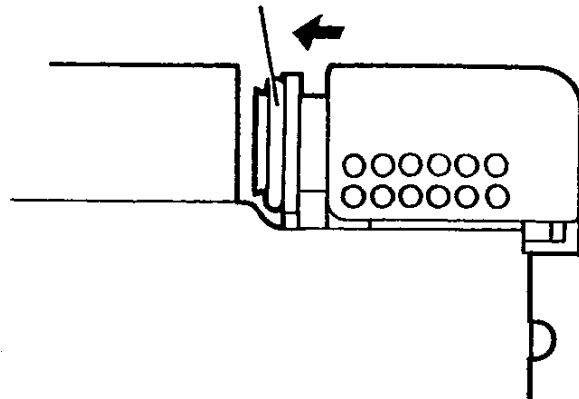

⑥ Assemble the heating element.

Attach the nozzle and securely tighten the nut with the attached spanner.

⚠ CAUTION

If the nut is loose, air will leak and the temperature will drop.

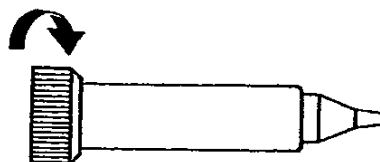

Replacing the Heating Element

⚠ WARNING

Unplug the power cord before starting this procedure.

The resistance value of a working heating element is $2-4\ \Omega$ at 23°C (73°F). If the value you get is outside this range, replace the heating element.

- 1 Disassemble the heating parts.
- 2 Separate the housing.
- 3 Detach the terminal and remove the heating element.
- 4 Insert a new heating element and reassemble. (Heating element 24V-50W)

⚠ CAUTION

Before reassembling enclosure, make sure connectors are completely covered by the glass tube.

- 5 Recalibrate the temperature.

The resistance of new heating element varies, resulting in variations in operating temperatures. It is necessary to recalibrate the temperature every time the heating element is replaced.

1. Set the temperature control knob to 1 and allow the gun to warm up for 3 minutes.
2. Measure the tip with a tip thermometer. Using a straight-edge (—) or small cross point screwdriver, adjust the temperature calibrator (marked "CAL") until the nozzle temperature reads 380°C (716°F). Turn the temperature calibrator clockwise to increase the temperature and counter-clockwise to reduce the temperature.

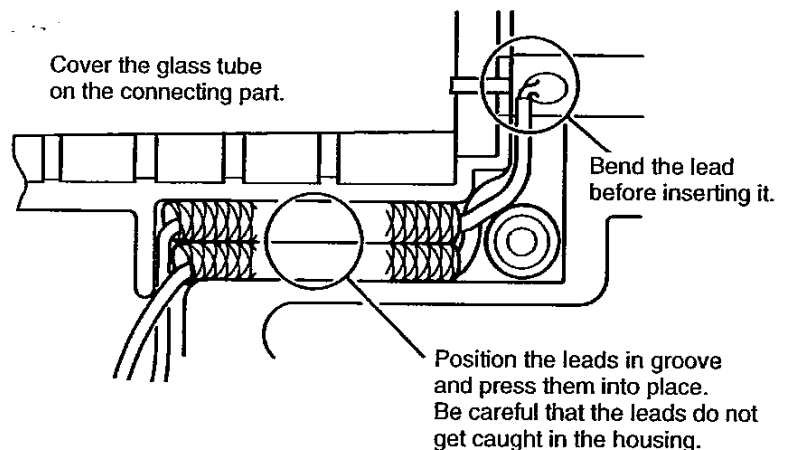
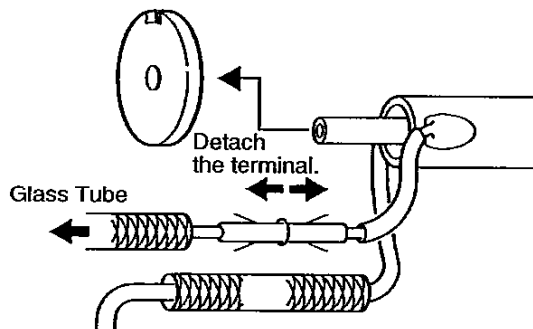
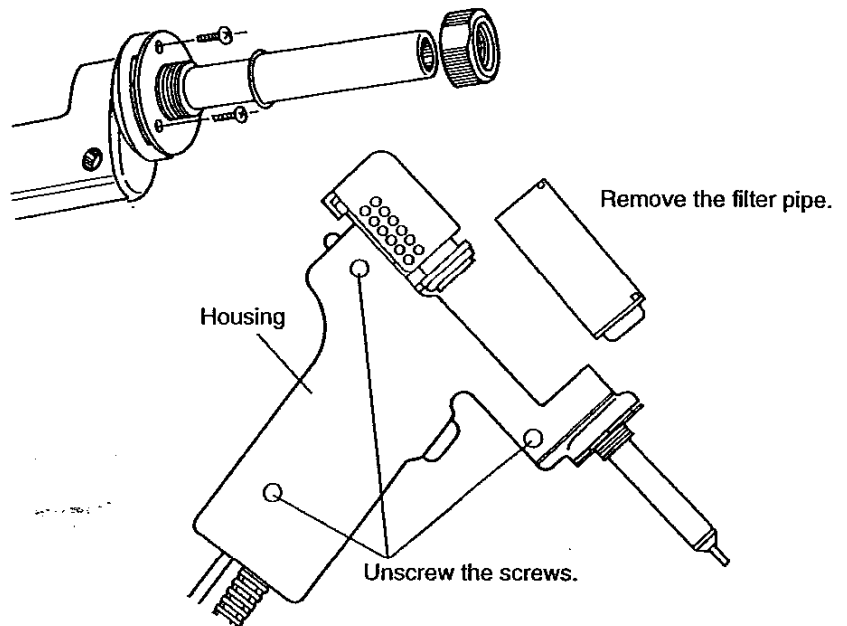

Maintenance (Station)

Cleaning the inside of the Filter Case

① Replace the ceramic paper filter (No. A1009).

Remove the ceramic paper filter and inspect it. If it is stiff with flux, replace it.

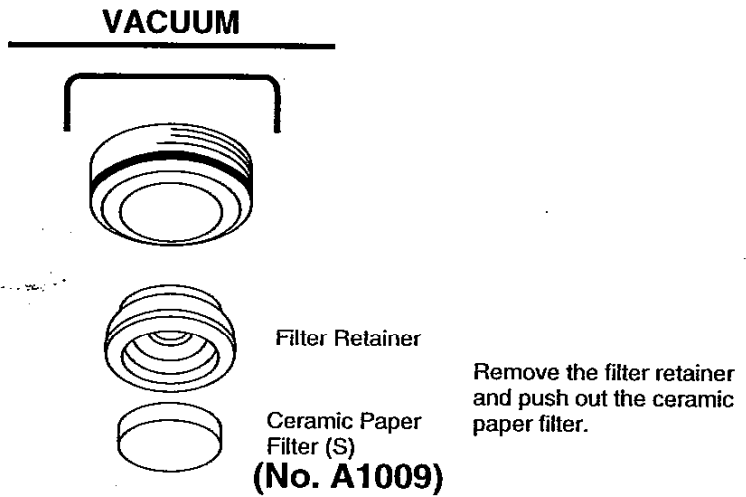

② Reassemble the filter case.

CAUTION
Set the ceramic paper filter (S) for the filter retainer (station). Using the ceramic paper filter (L) in the filter retainer may cause to break or the power to drop.

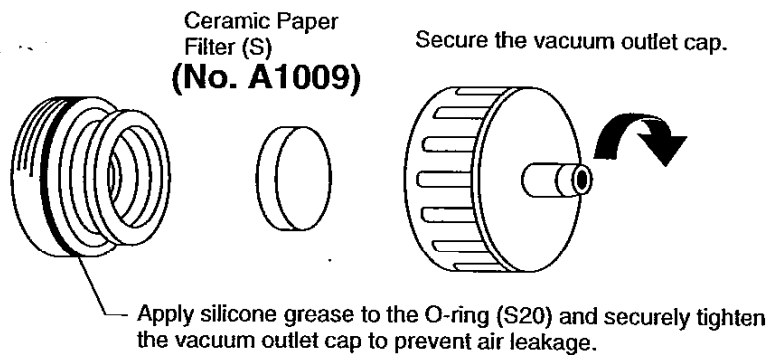

Cleaning the Pump

⚠ WARNING

Unplug the power cord before starting this procedure.

① Disassemble the pump heads.

1. Remove the rear panel.
2. Remove the cover.
Remove the pump head from each side of the pump.

② Clean the pump head.

1. Remove the valve plate and fixing plate.
2. Remove any flux adhering to the plates.

⚠ CAUTION

If the fixing plate is difficult to remove, apply hot air to it to warm it up. Never use excessive force to remove the plate as it is easy to bend, and a bent plate will allow air to leak out and reduce solder vacuuming efficiency.

⚠ CAUTION

Clean the plates only with alcohol or thinner.

Replace

If the valve plate is bent or stiff, replace it.

3. If the exhaust filter is dirty, replace it.

③ Assemble the pump heads.

Reassemble the valve plate and fixing plate.

⚠ CAUTION

When assembling the pump, be sure to check for air leaks.

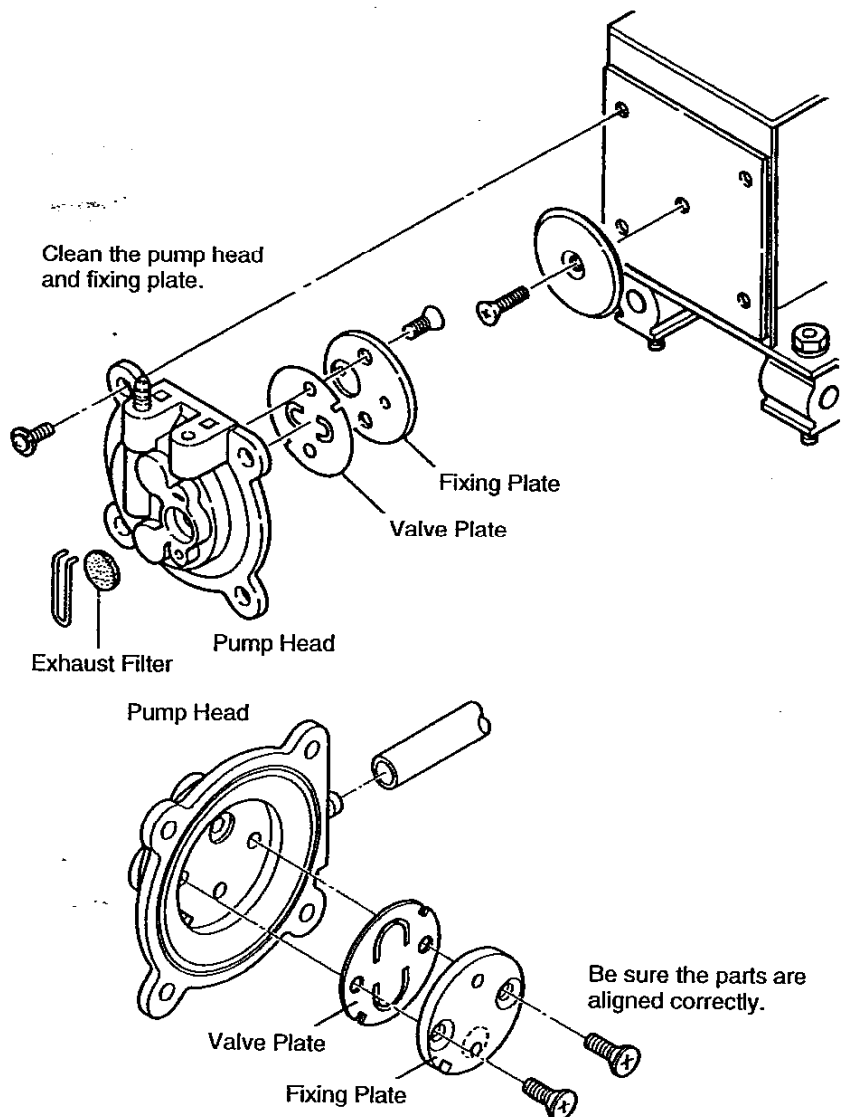

Troubleshooting Guide

Soldering and Desoldering

- **Power lamp does not light up.**
 - **Is the power cord plugged in correctly?**
Securely insert the power cord into the power supply.
 - **Is the fuse blown?**
Determine why the fuse blew and eliminate the cause, then replace the fuse.
 - a. Is the inside of the soldering iron or desoldering gun short-circuited?
 - b. Is the grounding spring touching the heating element?
 - c. Is the heating element lead twisted and short-circuited?

Soldering

- **The heater lamp lights up but the tip does not heat up.**
 - **Is the soldering iron cord broken ?**
Refer to 'Checking for breakage of the cord assembly.' (P.14)
 - **Is the heating element broken?**
Refer to 'Checking for breakage in the heating element.' (P.14)
- **The tip heats up intermittently.**
 - **Is the soldering iron cord broken?**
Refer to 'Checking for breakage of the cord assembly.' (P.14)
- **The tip is not wet.**
 - **Is the tip temperature too high?**
Set an appropriate temperature.
 - **Is the tip clean?**
Refer to 'Tip Care and Use'(P.6)
- **The tip temperature is too low.**
 - **Is the tip coated with oxide?**
Refer to 'Inspect and clean the tip'(P.13)
 - **Is the iron calibrated correctly?**
Recalibrate.
- **The tip can not be pulled off.**
 - **Is the tip seized?**
Is the tip swollen because of deterioration?
Replace the heating element and the tip.
- **The tip doesn't hold the desired temperature.**
 - **Is the iron calibrated correctly?**
Recalibrate.

Desoldering

● Pump does not operate.

- **Is the cord assembly properly connected?**
Reconnect the cord assembly.(refer to p.8)
- **Is the nozzle or hole in the heating element clogged?**
Clean it.(refer to p.15)

● Solder is not being absorbed.

- **Is the spring filter full of solder?**
Replace it with a new one.(refer to p.16)
- **Is the ceramic filter hardened?**
Replace it with a new one.
- **Is there a vacuum leak?**
Check the connections and replace any worn parts.
(refer to p.12)

● The nozzle does not heat up.

- **Is the desoldering gun cord assembly properly connected?**
Reconnect it.(refer to p.8)
- **Is the heating element damaged?**
Replace it. (refer to p.18)

Note : When repairs are needed please send both the desoldering gun and the station to your sales agent.

 **WARNING** : If the power cord is damaged, it must be replaced by the manufacturer, its service agent or similarity qualified person in order to avoid personal injury or damage to the unit.

Parts List (Station)

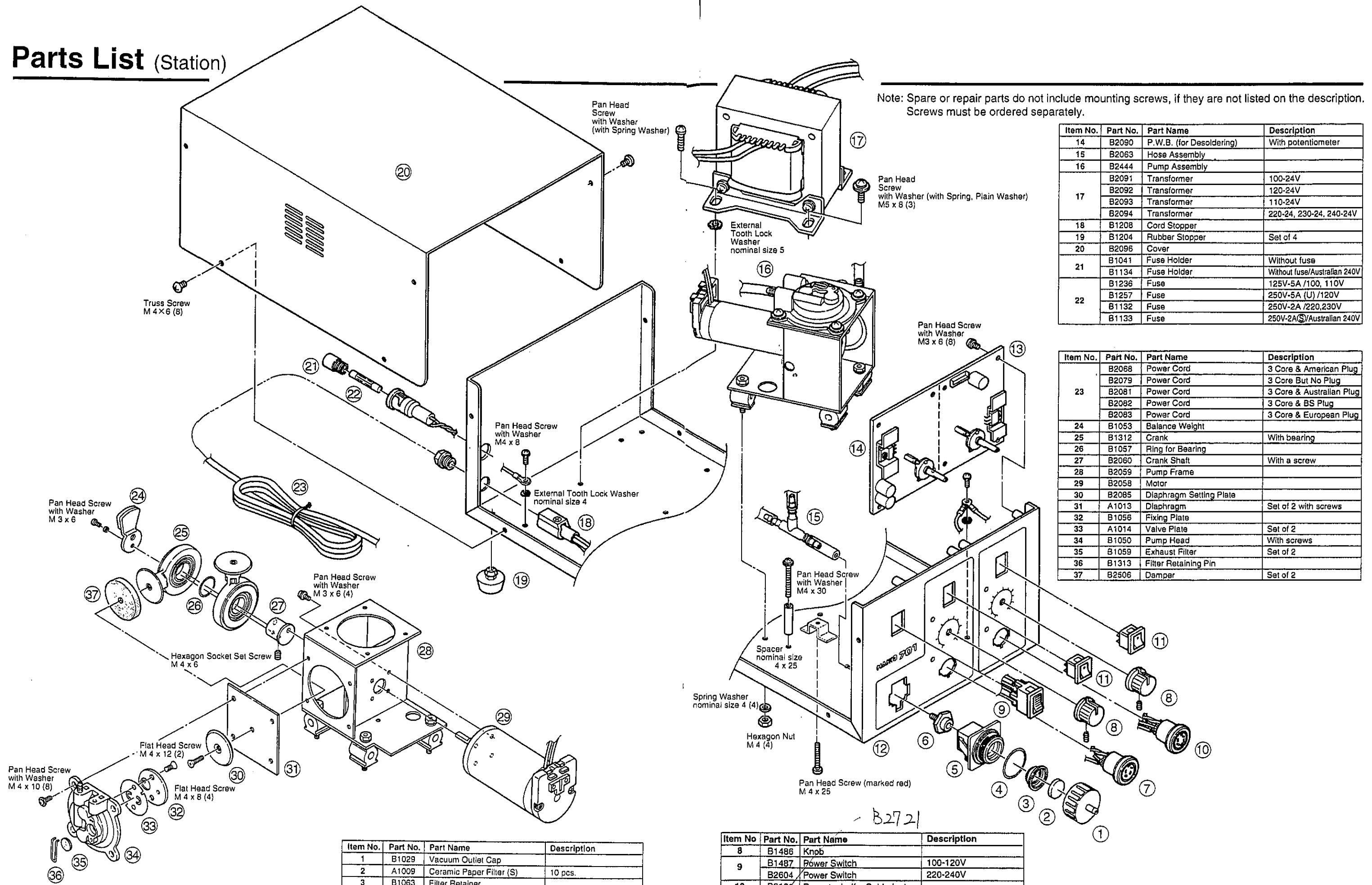

Item No.	Part No.	Part Name	Description
14	B2090	P.W.B. (for Desoldering)	With potentiometer
15	B2063	Hose Assembly	
16	B2444	Pump Assembly	
17	B2091	Transformer	100-24V
	B2092	Transformer	120-24V
	B2093	Transformer	110-24V
	B2094	Transformer	220-24, 230-24, 240-24V
18	B1208	Cord Stopper	
19	B1204	Rubber Stopper	Set of 4
20	B2096	Cover	
21	B1041	Fuse Holder	Without fuse
	B1134	Fuse Holder	Without fuse/Australian 240V
22	B1236	Fuse	125V-5A /100, 110V
	B1257	Fuse	250V-5A (U) /120V
	B1132	Fuse	250V-2A /220,230V
	B1133	Fuse	250V-2A(A) /Australian 240V

Item No.	Part No.	Part Name	Description
23	B2068	Power Cord	3 Core & American Plug
	B2079	Power Cord	3 Core But No Plug
	B2081	Power Cord	3 Core & Australian Plug
	B2082	Power Cord	3 Core & BS Plug
	B2083	Power Cord	3 Core & European Plug
24	B1053	Balance Weight	
25	B1312	Crank	With bearing
26	B1057	Ring for Bearing	
27	B2060	Crank Shaft	With a screw
28	B2059	Pump Frame	
29	B2058	Motor	
30	B2085	Diaphragm Setting Plate	
31	A1013	Diaphragm	Set of 2 with screws
32	B1056	Fixing Plate	
33	A1014	Valve Plate	Set of 2
34	B1050	Pump Head	With screws
35	B1059	Exhaust Filter	Set of 2
36	B1313	Filter Retaining Pin	
37	B2506	Damper	Set of 2

Item No.	Part No.	Part Name	Description
1	B1029	Vacuum Outlet Cap	
2	A1009	Ceramic Paper Filter (S)	10 pcs.
3	B1063	Filter Retainer	
4	B1034	O-ring (S20)	
5	B1031	Vacuum Outlet Retainer	With O-ring (S20)
6	B1064	Filter Case Joint	
7	B1036	Receptacle (for Desoldering)	

B2721

Item No	Part No.	Part Name	Description
8	B1486	Knob	
9	B1487	Power Switch	100-120V
	B2604	Power Switch	220-240V
10	B2101	Receptacle (for Soldering)	
11	B1064	Switch	
12	B2095	Chassis	
13	B2089	P.W. B. (for Soldering)	

Parts List (Desoldering Gun /

Iron Holder)

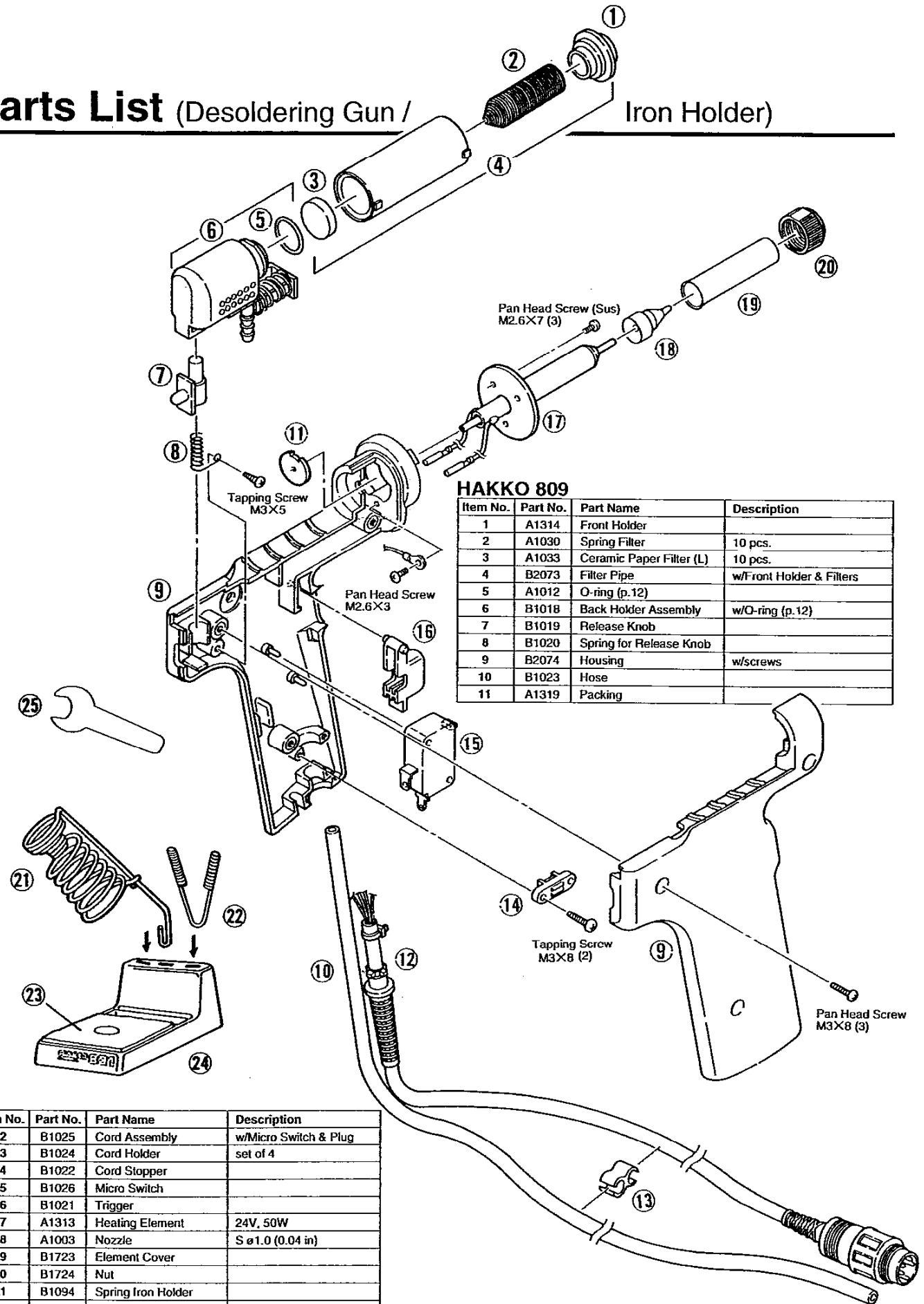

HAKKO 809

Item No.	Part No.	Part Name	Description
1	A1314	Front Holder	
2	A1030	Spring Filter	10 pcs.
3	A1033	Ceramic Paper Filter (L)	10 pcs.
4	B2073	Filter Pipe	w/Front Holder & Filters
5	A1012	O-ring (p.12)	
6	B1018	Back Holder Assembly	w/O-ring (p.12)
7	B1019	Release Knob	
8	B1020	Spring for Release Knob	
9	B2074	Housing	w/screws
10	B1023	Hose	
11	A1319	Packing	

Item No.	Part No.	Part Name	Description
12	B1025	Cord Assembly	w/Micro Switch & Plug
13	B1024	Cord Holder	set of 4
14	B1022	Cord Stopper	
15	B1026	Micro Switch	
16	B1021	Trigger	
17	A1313	Heating Element	24V, 50W
18	A1003	Nozzle	S ø1.0 (0.04 in)
19	B1723	Element Cover	
20	B1724	Nut	
21	B1094	Spring Iron Holder	
22	B1095	Cleaning Pin Holder	
23	A1042	Cleaning Sponge	
24	B1470	Iron Holder Base	
25	B2100	Spanner	

● Replacement Parts

No. A1002, A1003

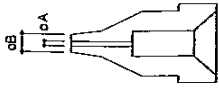

No. A1004-A1007

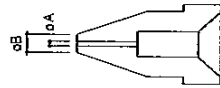

Part No.	Part Name / Specification	φ A	φ B
A1002	Nozzle S φ0.8 mm (0.03 in)	0.8 (0.03 in)	1.8 (0.07 in)
A1003	Nozzle S φ1.0 mm (0.04 in)	1.0 (0.04 in)	2.0 (0.08 in)
A1004	Nozzle φ0.8 mm (0.03 in)	0.8 (0.03 in)	2.3 (0.09 in)
A1005	Nozzle φ1.0 mm (0.04 in)	1.0 (0.04 in)	2.5 (0.1 in)
A1006	Nozzle φ1.3 mm (0.05 in)	1.3 (0.05 in)	3.0 (0.12 in)
A1007	Nozzle φ1.6 mm (0.06 in)	1.6 (0.06 in)	3.0 (0.12 in)

Part No.	Part Name / Specification
B1215	Cleaning Pin for Heating Element
A1086	Cleaning Pin for φ0.8 mm (0.03 in) Nozzle
B1087	Cleaning Pin for φ1.0 mm (0.04 in) Nozzle
B1088	Cleaning Pin for φ1.3 mm (0.05 in) Nozzle
B1089	Cleaning Pin for φ1.6 mm (0.06 in) Nozzle
B1302	Cleaning Drill for φ0.8 mm (0.03 in) Nozzle
B1303	Cleaning Drill for φ1.0 mm (0.04 in) Nozzle
B1304	Cleaning Drill for φ1.3 mm (0.05 in) Nozzle
B1305	Cleaning Drill for φ1.6 mm (0.06 in) Nozzle
A1028	Silicone Grease

Parts List (Iron/Iron Holder)

HAKKO 907ESD

Item No.	Part No.	Part Name	Description
1	B1784	Nut	
2	B1786	Tip Enclosure	
3		Soldering Tip	Sec. P. 13
4	B2022	Nipple	
5	B2032	Grounding Spring	
6	A1321	Heating Element	Old part No.900M-H,900L-H
7	B2028	Terminal Board	
8	B2024	Handle	w/Handle Cover, E.S.D.
9	B2027	Handle Cover	
10	B2031	Cord Bushing	
11	B2030	Cord Ass'y	E.S.D.

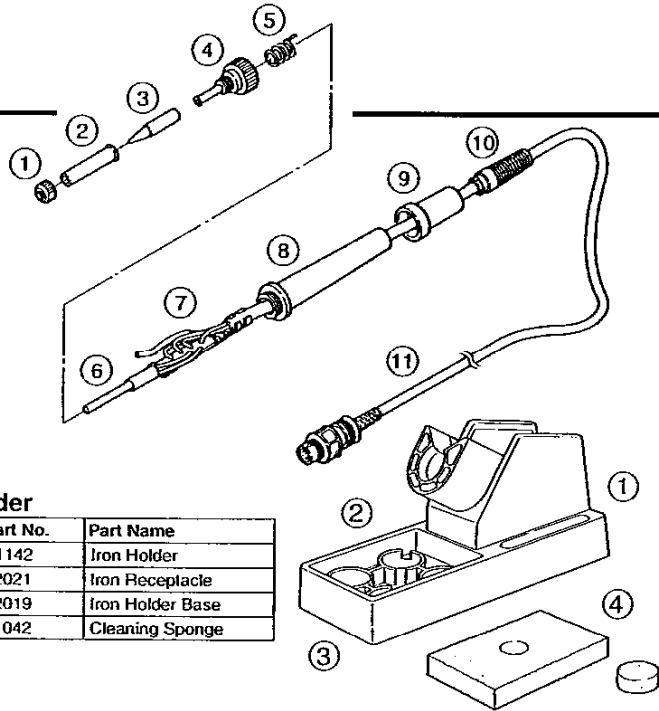

Iron Holder

Item No.	Part No.	Part Name
1	C1142	Iron Holder
2	B2021	Iron Receptacle
3	B2019	Iron Holder Base
4	A1042	Cleaning Sponge

Specifications

Name	HAKKO 701
Power Consumption	150W

Station

	Station
Output Voltage	24 V ~
Vacuum-Generator	Vacuum pump, double cylinder type
Vacuum Pressure (Max)	80kpa (600 mm Hg) (24in. Hg)
Suction Flow	15 l/min
Outer Dimensions (W x D x H)	190 x 250 x 130 mm (7.48 x 9.84 x 5.12 in)
Weight	5.0 kg (11.02lbs.)

• Specifications are subject to change without notice.

Soldering Iron

Part Name	HAKKO 907ESD
Part No.	C1144
Power Consumption	24V~ 50W
Temperature Range	200°C~480°C/392°F~896°F
Tip to Ground Resistance	Under 2 Ω
Tip to Ground Potential	Under 2mV (TYP. 0.6mV)
Cord Assembly	1.2m (4 ft.)
Total Length (w/o cord)	190mm (7.5 in.)
Weight (w/o cord)	44g (0.09 lbs.)

Desoldering Gun

Part Name	HAKKO 809
Part No.	C1183
Power Consumption	24V~ 50W
Temperature	380°C ~ 480°C (716°F ~ 896°F)
Nozzle to Ground Resistance	Under 2 Ω
Nozzle to Ground Potential	Under 2mV (TYP. 1.2mV)
Cord/Hose	1.2m (4 ft.)
Outer Dimensions(WXH)	135X174 mm (5.31X6.85 in)
Weight(w/o cord, hose)	Approx. 200g (0.44 lbs.)

Wiring Diagram

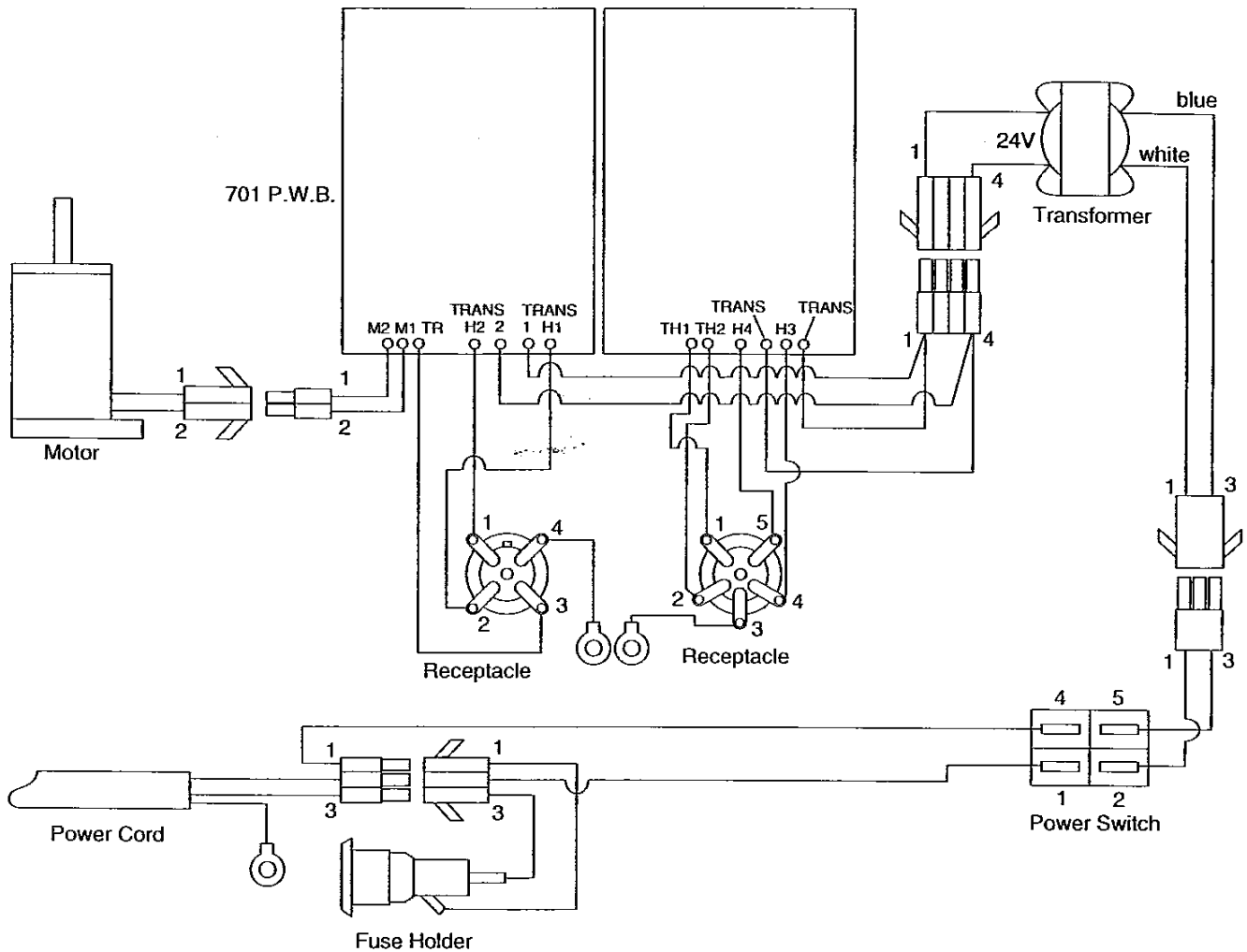

HAKKO CORPORATION

OVERSEAS AFFILIATES
 U.S.A.: AMERICAN HAKKO PRODUCTS, INC.
 28820 N. AVENUE WILLIAMS VALENCIA, CA 91355, U.S.A.
 TEL: (661) 294-0090 FAX: (661) 294-0096
 Toll Free (800) 884-HAKKO
 http://www.hakkousa.com
 HONG KONG: HAKKO DEVELOPMENT CO., LTD.
 ROOM 1504, EASTERN HARBOUR CENTRE,
 23 HOK CHAK STREET, QUARRY BAY, HONG KONG.
 TEL: 2811-5588 FAX: 2580-0217
 http://www.hakko.com.hk
 E-mail: hko@hakkocom.hk
 CHINA: HAKKO DEVELOPMENT CO., LTD.
 ROOM 1112-1115, 11 FLOOR, INTERNATIONAL BANK
 TOWER 191 DONGFENG ROAD WEST, GUANGZHOU
 510180, CHINA.
 TEL: (020) 8135-0112, 8135-0113 FAX: (020) 8135-0181
 http://www.hakko.com.hk
 E-mail: hako@public.guangzhou.gd.cn

HEAD OFFICE
 4-5, SHIOKUSA 2-CHOME, NANIWA-KU, OSAKA, 556-0024 JAPAN
 TEL: +81-6-6561-3225 FAX: +81-6-6561-8466
 http://www.hakko.com E-mail: sales@hakko.com
 TAIWAN: HAKKO DEVELOPMENT CO., LTD.
 5F, NO. 111-1, HSING TE RD., SANCHUNG, TAIPEI
 HSIEN, TAIWAN, R.O.C.
 TEL: (02) 8512-4588 FAX: (02) 8512-4258
 E-mail: hako110@ms31.hinet.net
 SINGAPORE: HAKKO PRODUCTS PTE., LTD.
 1, GENTING LINK #02-04, PERFECT INDUSTRIAL
 BUILDINGS, SINGAPORE 349518
 TEL: 748-2277 FAX: 744-0033
 http://www.hakko.com.sg
 E-mail: sales@hakko.com.sg
 MALAYSIA: HAKKO PRODUCTS SDN BHD
 MALAYSIA HEAD OFFICE
 NO. 22, JALAN PEMBERTA U1/H9, SEKSYEH U1,
 TEMASAS INDUSTRIAL PARK, 40150 GLENMARIE,
 SHAH ALAM, SELANGOR DARUL EHSAN, WEST MALAYSIA.
 TEL: (03) 5689-5223 FAX: (03) 5689-5221
 E-mail: hako@tm.net.my

PERANG BRANCH
 19 LONONG IKS JURU 3, TAMAN PERINDUSTRIAN RINGAN JURU,
 14100 SEBERANG PERAI TENGAH, PENANG, MALAYSIA.
 TEL: (04) 507-0888 FAX: (04) 507-0999 E-mail: hako@tm.net.my
JOHOR BAHRU BRANCH
 45A, JALAN SRI BAHAGIA 5, TAMAN SRI BAHAGIA,
 81200 JALAN TAMBELI, JOHOR BAHRU, MALAYSIA.
 TEL: (07) 236-7766 FAX: (07) 237-4655
 E-mail: hako@tm.net.my
PHILIPPINES: HAKKO PHILS TRADING CO., INC.
 GROUND FLOOR HAKKO BUILDING 1ST STREET CORNER
 3RD STREET UNITED PARANAGUE 5, SUBDIVISION SAN KRONSID
 PARANAGUE CITY PHILIPPINES
 TEL: (02) 825-5404, 826-6165 FAX: (02) 829-3763
 E-mail: hako@phl@pacific.net.ph
INDONESIA: P.T. HAKKO PRODUCTSTAMA INDONESIA
BATAM BRANCH
 COMPAK BUMI INDAH BLOK IV NO. 40 NAGOYA BATAM, INDONESIA.
 TEL: (77) 857-453 FAX: (77) 452-772 E-mail: hako@tm@indosat.net.id
JAKARTA BRANCH
 KEBON JERUK PLAZA, BLOK D NO. 6, JALAN RAYA PERJUANGAN,
 JAKARTA BARAT, 11530, INDONESIA.
 TEL: (21) 532-4083 FAX: (21) 532-4082 E-mail: hako@tm@cbn.net.id