

HAKKO 938

SOLDERING STATION

Instruction Manual

●

Thank you for purchasing the HAKKO 938 desoldering tool.
Please read this manual before operating the HAKKO 938.
Keep this manual readily accessible for reference.

●

TABLE OF CONTENTS

1. PACKING LIST	35
2. SPECIFICATIONS	35
3. WARNINGS, CAUTIONS AND NOTES	36
4. SETTING UP	37
5. OPERATION	38
6. PARAMETER SETTINGS.....	41
7. MAINTENANCE	43
8. CHECKING PROCEDURE	44
9. ERROR MESSAGES	45
10. TROUBLE SHOOTING GUIDE	46
11. TIP STYLES	47
12. PARTS LIST	48
13. WIRING DIAGRAM	50

1. PACKING LIST

Control card	1	Iron holder	1
Station	1	Heat resistant pad	1
HAKKO 917 Soldering iron.....	1	Power cord	1
		Instruction manual	1

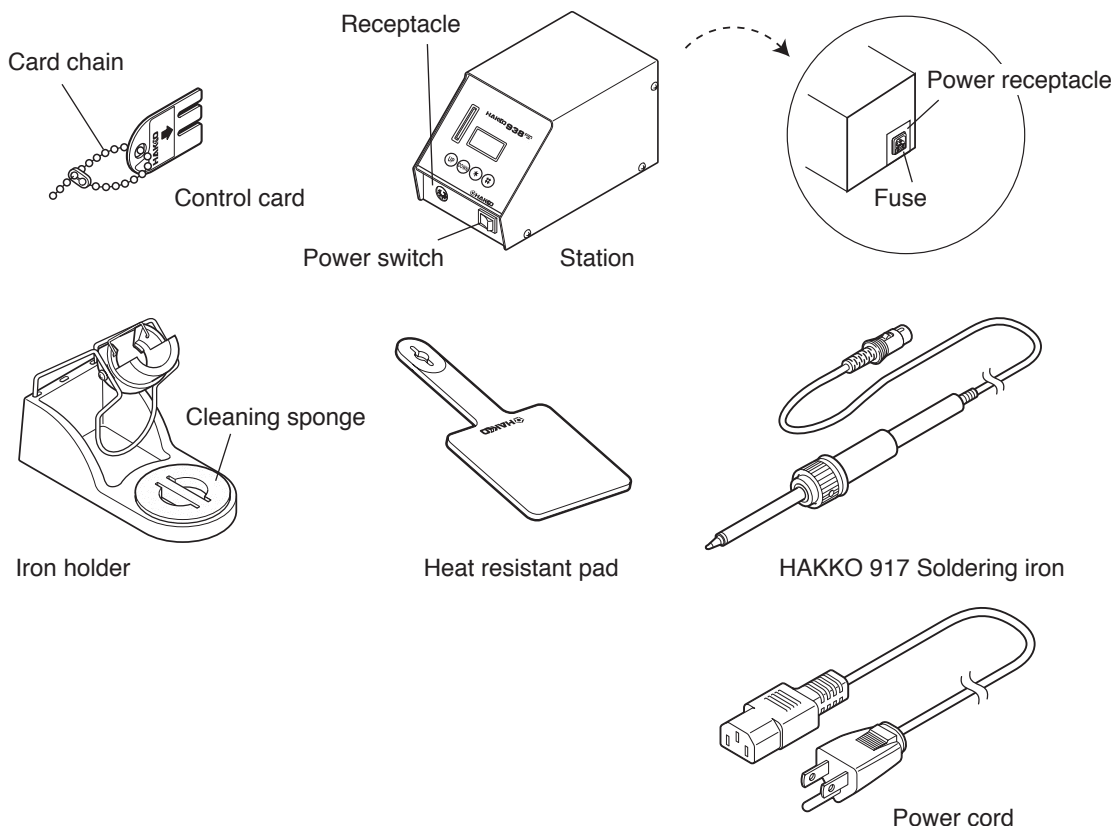

2. SPECIFICATIONS

● HAKKO 938 soldering station

Power consumption	100 W
Temperature range	200 - 450°C (400 - 840°F)
Temperature stability	±2°C (±4°F) at idle temperature

● Station

Output	27 V 3.4 A
Dimensions	100 (W) × 106 (H) × 188 (D) mm
Weight	2.5 Kg

● HAKKO 917 soldering iron

Power consumption	90 W (27 V)
Standard tip	T10 - D24
Tip to ground resistance	< 2 Ω
Tip to ground potential	< 2 mV
Length, less cord	175 mm (When 2.4D tip is inserted)
Weight, less cord	45g (When 2.4D tip is inserted)
Length of cord	1.2 m

NOTE:

The temperatures were measured using the HAKKO 191 thermometer.

This product is protected against electrostatic discharge. Specifications and design are subject to change without notice.

3. WARNINGS, CAUTIONS AND NOTES

WARNING

In this instruction manual, “WARNING” and “CAUTIONS” are defined as follows.

 **WARNING:** Misuse may potentially cause death of, or serious injury to the user.

 **CAUTION :** Misuse may potentially cause injury to the user or physical damage to the objects involved.
For your own safety, be sure to comply with these precautions.

Failure to do so may result in serious problems.

CAUTION

When the power is on, the nozzle temperature is between 200°C/392°F and 450°C/ 896°F. Since mishandling may lead to burns or fire, be sure to comply with the following precautions.

- Do not touch the tip or the metal parts near the tip.
- Do not allow the tip to come close to, or touch, flammable materials.
- Inform others in the area that the unit is hot and should not be touched.
- Turn the power off when not in use, or left unattended.
- Turn the power off when changing parts or storing the HAKKO 938.

To prevent accidents or damage to the HAKKO 938, be sure to observe the following:

- Do not use the HAKKO 938 for applications other than soldering.
- Do not allow the HAKKO 938 to become wet, or use it when hands are wet.
- Do not modify the HAKKO 938.
- Use only genuine Hakko replacement parts.
- Do not bend or damage the control card. If the card does become damaged, do not force the card into the station slot.
- Do not strike the iron against hard objects to remove excess solder. This will damage the iron.
- Remove power and iron cords by holding the plug – not the wires.
- Be sure the work area is well ventilated. Soldering produces smoke.
- The HAKKO 938 is not intended for use by children or infirm persons without supervision.
- Children should be supervised to ensure that they do not play with the HAKKO 938.

4. SETTING UP

日本語

中文

English

A. Iron holder

The sponge is compressed. It will swell when moistened with water.

Before using the unit, dampen the sponge with water and squeeze it dry.

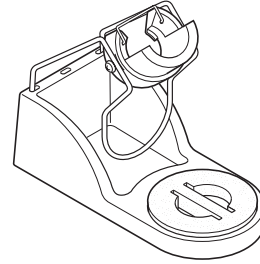

⚠ CAUTION

Using the sponge without dampen with water may damage the tips.

B. Handpiece

Pass the iron cord through the hole in the heat resistant pad.

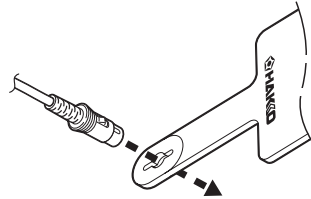

C. Soldering station

⚠ CAUTION

Be sure the power switch is OFF before connecting or disconnecting the soldering iron cord. Failure to do so may result in damage to the circuit board.

1. Insert the power cord into the receptacle at the back of the station.
Insert the soldering iron cord into the receptacle at the front of the station.
2. Set the iron in the iron holder.
3. Plug the power cord into a grounded wall socket. The HAKKO 938 is protected against electrostatic discharge and must be grounded for full efficiency.

When the plug 'clicks', it is fully inserted

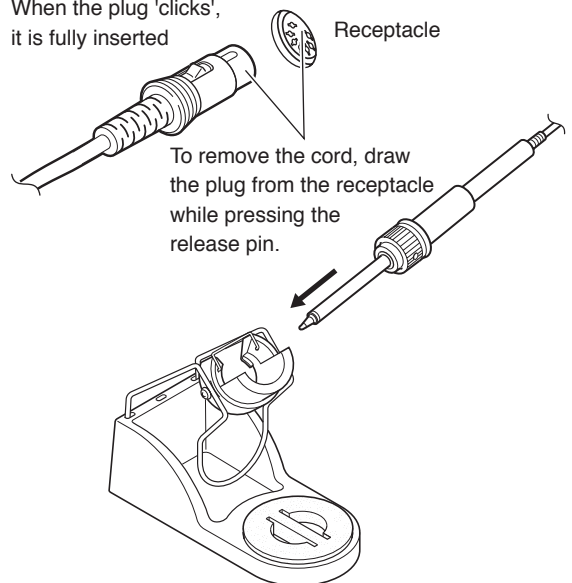

5. OPERATION

Controls and displays

Controls

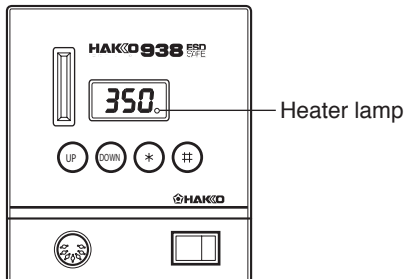

The front panel of the HAKKO 938 soldering station has the following controls:

- A power on/off switch.
- Four control buttons:

- #** – Initiates a data entry mode.
- *** – End of sequence signal (terminates a phase of a data entry mode); when pressed for less than one second, displays settings already stored.
- UP** – increases the value in the appropriate display window.
- DOWN** – decreases the value in the appropriate display window.

1. Turn the power switch ON.
2. Once the temperature is reached, the buzzer sounds. The heater lamp at the lower right of the temperature display **350** starts blinking.

Displays

The HAKKO 938 has a three-digit display element. Depending upon the selected mode, it will display:

- Normal mode:
Sensor temperature (tip temperature)
- Data entry:
Selected quantity (see 'data entry procedures' for exact characteristics)
- Temperature scale:
°C or °F, depending upon selection
- Error detection:
Refer to 'ERROR MESSAGES' section

In addition, a single heater lamp will flash when the station has reached the desired temperature, indicating that it is ready for use.

An audible buzzer is provided to alert the operator when:

- The station has reached the set temperature. The buzzer will sound once.
- The low temperature threshold has been crossed. This buzzer will shutoff when the sensed temperature returns to the acceptable range.
- A failure has occurred in the sensor or heater (including the sensor circuit). The buzzer will sound continuously.
- The auto power shutoff is activated and the power to the heating element is shutoff, the buzzer will sound three times.

CAUTION

The HAKKO 938 is preset at 350°C. at the factory. Check the temperature setting by pressing the ***** button. The set temperature will be displayed for two seconds.

CAUTION

Place the iron in the iron holder when not in use.

5. OPERATION

● Changing the temperature setting

Example: 350° to 400°C

1. Insert the control card into the slot in the front of the unit.
 - The *hundreds* digit will begin to flash, indicating that the unit is in the TEMPERATURE SET mode and data may be entered.
2. Entering the *hundreds* digit
 - Press the **UP** or **DOWN** button to set the desired figure. Only 2, 3, or 4 can be selected. (In °F mode, 4, 5, 6, 7, or 8 can be selected). When the desired figure is displayed, press the **✳** button to enter. The *tens* digit will begin to flash.
3. Entering the *tens* digit
 - Press the **UP** or **DOWN** button to set the desired figure. Any value from 0 to 9 can be selected. When the desired figure is displayed, press the **✳** button to enter. The *units* digit will begin to flash.
4. Entering the *units* digit
 - Press the **UP** or **DOWN** button to set the desired figure. When the desired figure is displayed, press the **✳** button to enter. The desired temperature is now entered into the system memory and heater control will begin.

⚠ CAUTION

The card must be inserted into the card slot in the correct direction. The heater is off while you are setting the temperature.

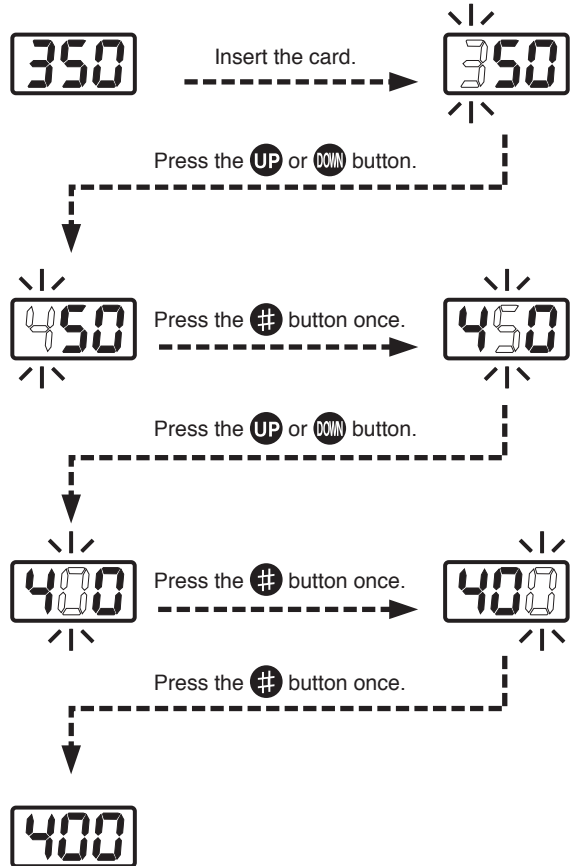

NOTE:

If power is switched off or lost during the execution of this procedure, no data will be entered. The entire procedure must be repeated from step 1.

When the station is ON and the card is in the station, the data entry procedure follows:

1. Hold the **✳** button down for at least one second.
2. The current temperature setting will be displayed, then the hundreds digit will begin to flash. This indicates that the station has entered the temperature setting mode.
3. Continue with the procedure of 2-4, above.

NOTE:

When the button is pressed for less than one second, the current temperature setting is displayed.

● Replacing the tip

1. Always turn the power OFF when removing or inserting a tip.
2. Turn around the nipple slightly and then hold the tip with the heat resistant pad and pull it out.
3. Insert the new tip fully into the HAKKO 917 and then lock the nipple. The socket of the tip has an orientation. If the tip is not fully inserted, the display will show a sensor error [S-E] when power is turned on.

⚠ CAUTION

The tip will be HOT! Use the heat resistant pad to remove it. Do not hold the tip with the heat resistant pad for an extended time.

⚠ CAUTION

Turn around the nipple approximately 180° counterclockwise, then replace the tip. Be careful not to loosen the nipple too much. Otherwise it may be broken.

● How to enter the tip offset value into the HAKKO 938

Example 1

If the measured temperature is 410°C and the set temperature is 400°C, the difference is -10°C (need to decrease by 10°C). So, enter the value subtracting 10 from the current offset value.

1. Insert the control card into the slot in the station.
 - The station will default to the temperature setting mode. Set the temperature at 400°C. (750°F.).
2. Press the # button on the front panel and hold for one second.
 - This will set the station to the offset value entry mode.
 - Press the UP or DOWN button to set the desired figure. Only 2, 3, or 4 can be selected. (In °F mode, 4, 5, 6, 7, or 8 can be selected).
 - When the desired figure is displayed, press the * button to enter. The tens digit will begin to flash.
3. Measure the tip temperature.

NOTE:

Allow the tip temperature to become stable. During offset data entry mode, the tip temperature is controlled by presented offset value.

4. Enter the offset value

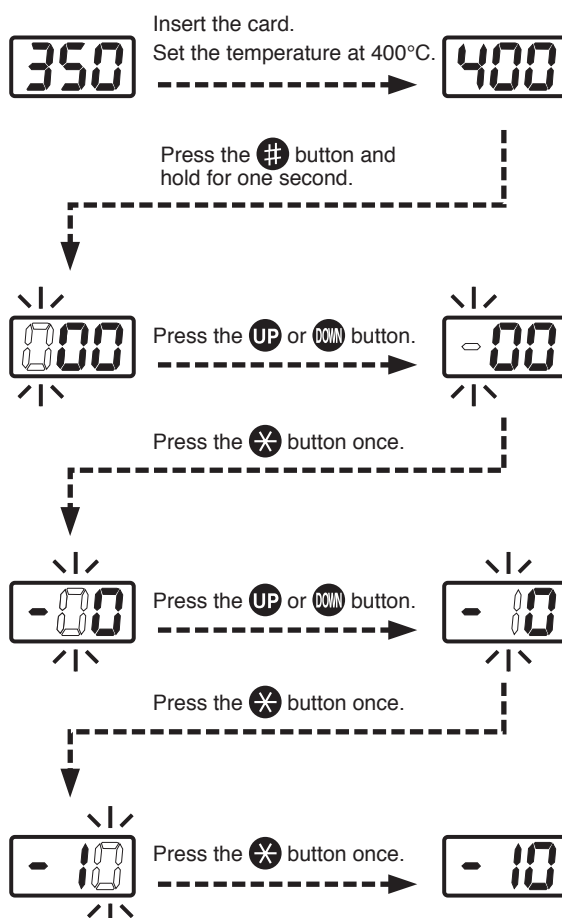

NOTE:

When the unit is in offset-free mode, you can go into the offset value entry mode without control card by pressing the # button for one second.

6. PARAMETER SETTINGS

The HAKKO 938 comes from the factory with the following values preset:

Temperature scale	Celsius
Power save	disabled
Low temperature alarm setting	150°C
Resetting the supervisor/operator control setting	4 0
Set temperature	350°C

● Entering the parameters 1 °C or °F temperature display

2 Power save setting

Power save is an optional setting HAKKO 938 has two kinds of power save functions. To turn off the power save function, select 0 and then press the **✖** button.

Power save function setting:

2 0	Disabled	
2 15	Sleep	work after 15 minutes rest
2 30	Auto power shutoff	work after 30 minutes rest

- When the display shows **SLP**, pressing any button the power will be turned on again.
- When the display shows **---**, and to begin soldering, cycle the power switch OFF, then ON.

The HAKKO 938 has the following four parameters:

- 1) °C or °F temperature display selection
- 2) Power save
- 3) Low-temperature alarm tolerance setting
- 4) Resetting the supervisor/operator control setting

Once the station enters parameter mode, set the parameters in the order shown below. After all the parameters have been set, normal operation will be resumed.

1. Turn power OFF.
2. Insert the control card into the card slot in the front of the unit.
3. Press and hold down the **UP** and **DOWN** buttons simultaneously, and then turn power ON.
4. Hold **UP** and **DOWN** buttons down until the display shows **1 C** (Celsius) or **1 F** (Fahrenheit). When either the display shows either **1 C** or **1 F**, the station is in parameter input mode.
 - Pressing either the **UP** and **DOWN** button will cause the display to alternate between **1 C** or **1 F**.
 - When the desired scale is displayed, select by pressing the **✖** button. The system will automatically sequence to power save mode.

When the station enters the parameter input mode, the procedure is as follows.

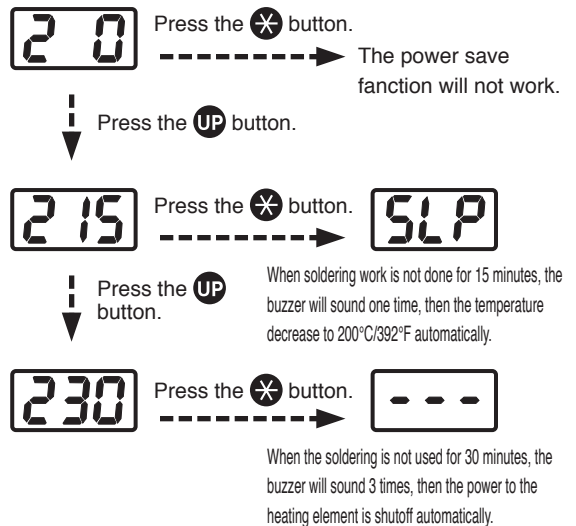

3 Resetting the low temperature alarm tolerance setting

This unique function alerts the operator when the sensed temperature falls below a set limit. If the sensed temperature drops below the alarm level, an error message **H-E** will be displayed, and the buzzer will sound. When the temperature returns within the allowable range, the buzzer will stop. The value is stored in the HAKKO 938 as described in the example below:

EXAMPLE:

If the set temperature is 350°C. and the low temperature alarm is 100°C., the alarm will trip when the sensed temperature drops below 250°C.

To bypass this procedure, press the **✖** button three times.

Range of allowable low-temperature alarm tolerance
For °C: 30 – 150°C
For °F: 50 – 300°F

4 Resetting the supervisor/operator control setting

- When the station enters low-temperature alarm tolerance setting mode, the hundreds digit begun flashing. Enter and store the value in the same manner as described in “Changing the temperature setting.”
- If you enter a value exceeding the allowable range shown to the left, you will be brought back to entering a value in the hundreds digit. If this occurs, re-enter a correct value.
- Once the value is stored, the system will automatically sequence to the resetting the supervisor/operator control setting.

NOTE:

The threshold limits are: 30 – 150°C.; 50 – 300°F. If a value exceeding these limits should be entered, the system will revert to the beginning of the mode (the hundreds digit will flash) and the procedure must be begun anew.

To change the supervisor/operator control settings, the procedure is as follows.

- The display will show **4 0** or **4 1** when this mode is entered.

4 0 : No offset value can be entered without inserting the card.

4 1 : An offset value can be entered without inserting the card.

Pressing the **UP** or **DOWN** button will change **4 0** and **4 1**.

When the desired setting is displayed, select by pressing **✖** button.

The system will exit the parameter setting mode and begin heater control.

It is now ready for normal operation.

7. MAINTENANCE

日本語

中文

English

● Tip maintenance

1. Tip temperature

High temperatures shorten tip life and may cause thermal shock to components. Always use the lowest possible temperature when soldering. The excellent thermal recovery characteristics of the HAKKO 938 ensure effective soldering at low temperatures.

2. Cleaning

Always clean the soldering tip before use, to remove any residual solder or flux adhering to it. Use a clean and moist cleaning sponge (provided with the HAKKO 938) or the HAKKO 599B tip cleaner. Contaminants on the tip have many deleterious effects, including reduced heat conductivity, which contribute to poor soldering performance.

3. After use

Always clean the tip and coat it with fresh solder after use. This guards against oxidation.

4. When the unit is not being used and the auto power shutoff is not active.

Never allow the unit to idle at a high temperature for extended periods. This will allow the tip to become oxidized. Turn the power switch OFF. If it is to be out of service for several hours, it is advisable to pull the power plug as well.

5. Inspecting and cleaning the tip

This procedure, if followed daily, will materially add to tip life.

1. Set the temperature to 250°C. (482°F.)
2. When the temperature stabilizes, clean the tip (see 2, above) and check the condition of the tip. If the tip is badly worn or deformed, replace it.
3. If the solder plated part of the tip is covered with black oxide, apply fresh solder, containing flux, and clean the tip again. Repeat until all the oxide is removed, then coat the tip with fresh solder.
4. Turn the power OFF and remove the tip, using the heat resistant pad. Set the tip aside to cool.
5. Remaining oxides, such as the yellow discoloration on the tip shaft, can be removed with isopropyl alcohol.

⚠ CAUTION
NEVER file the tip to remove oxides!

8. CHECKING PROCEDURE

■ Check for a broken heater or sensor

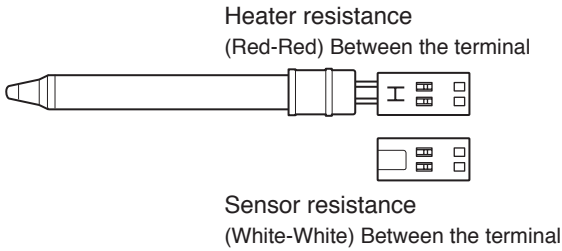

■ Check the grounding line

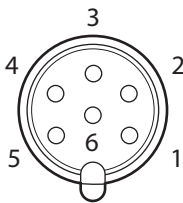

■ Checking the connection cord for breakage

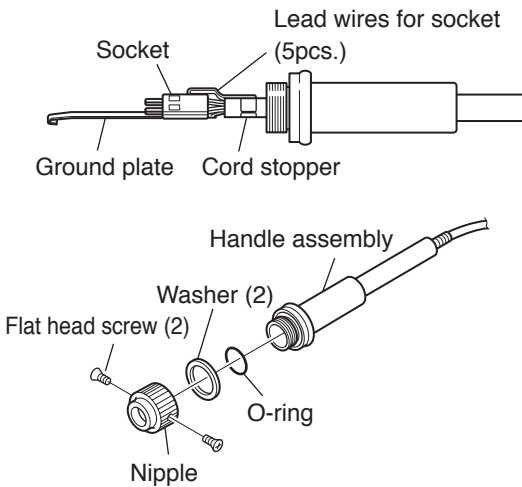

■ Replacing the fuse

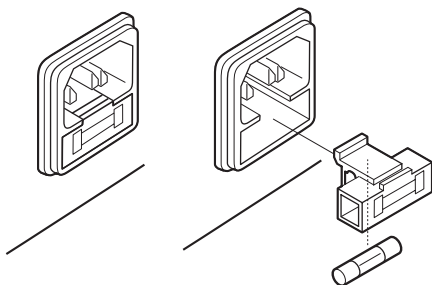

1. Check for a broken heater or sensor

Heater resistance (Red-Red)	1.8 - 2.6Ω (Normal)
Sensor resistance (White-White)	43 - 58Ω (Normal)

If the values are outside the above value, replace the tip.

1. Unplug the connection cord from the station.
2. Measure the resistance value between Pin 3 and the tip.
3. If the value exceeds 2Ω (at room temperature), perform the tip maintenance described on p.43. If the value still does not decrease, check the connection cord for breakage.

1. Remove the soldering tip and the nipple.
2. Push the socket out from inside the handle assembly.
3. Measure the resistance values between the connector and the lead wires at the socket as follows:

Pin 1 – Blue Pin 2 – White Pin 3 – Green
Pin 4 – Red Pin 5 – Black

If any value exceeds 0Ω or is ∞, replace the handle assembly.

⚠ CAUTION

Do not lose all of the spare parts.
When reassembling, match the convex part of the handle assembly with the concave parts of the socket.

1. Unplug the power cord from the power receptacle.
2. Remove the fuse holder.
3. Replace the fuse.
4. Put the fuse holder back in place.

9. ERROR MESSAGES

When trouble occurs with HAKKO 938, the following error message will display.
If the error message occurs, see section "10. TROUBLE SHOOTING GUIDE" on page 48.

日本語

中文

English

● Sensor Error



When there is the possibility that a failure has occurred in the sensor or heater (including the sensor circuit), **S-E** is displayed and the power is shut down with the buzzer sounding continuously.

⚠ CAUTION

The sensor error also occurs if the tip is not inserted properly. Once the tip is inserted properly, the HAKKO 938 is restarted.

● Low-temperature alarm tolerance error

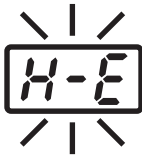

If the sensor temperature falls below the difference between the current temperature setting and the low-temperature alarm tolerance, is displayed and the warning buzzer sounds. When the tip temperature rises to a value within the set tolerance, the buzzer will stop sounding.

EXAMPLE:

Assume that the temperature setting is 400°C./750° F. and the tolerance 50°C./100°F. If the temperature continues to decrease and finally falls below the value indicated below while the heating element is on, the displayed value starts blinking to indicate that the tip temperature has dropped.

350°C (400°C - 50°C)

Set temperature Low-temperature alarm tolerance

OR

650°F (750°F - 100°F)

Set temperature Low-temperature alarm tolerance

10. TROUBLE SHOOTING GUIDE

WARNING:

- Do not disassemble the unit, or you may have an electric shock.

- The unit does not operate when the power switch is turned on.

- The tip does not heat up.

- The sensor error **S-E** is displayed.

- Solder does not wet the tip.

- The tip temperature is too high.

- The tip temperature is too low.

- The low-temperature alarm tolerance error occurs frequently.

CHECK : Is the power cord and/or the connection plug disconnected?

ACTION : Connect it.

CHECK : Is the fuse blown?

ACTION : Investigate why the fuse blew and then replace the fuse. If the cause can not be determined, replace the fuse. If the fuse blows again, send the unit in for repair.

CHECK : Is the power cord and/or the connection plug disconnected?

ACTION : Connect it.

CHECK : Is the tip inserted properly?

ACTION : Insert the tip completely.

CHECK : Is the connection cord and/or the heater/sensor broken?

ACTION : See the appropriate section of this manual regarding how to check the connection cord and/or the heater/sensor for breakage.

CHECK : Is the tip temperature too high?

ACTION : Set the appropriate temperature.

CHECK : Is the tip contaminated with oxide?

ACTION : Remove the oxide (see "Tip maintenance" on P. 43).

CHECK : Is the connection cord broken?

ACTION : See "Checking the connection cord for breakage" on P. 44.

CHECK : Is the entered offset value correct?

ACTION : Enter the correct value.

CHECK : Is the tip contaminated with oxide?

ACTION : Remove the oxide (see "Tip maintenance" on P. 43).

CHECK : Is the entered offset value correct?

ACTION : Enter the correct value.

CHECK : Is the tip contaminated with oxide?

ACTION : Remove the oxide (see "Tip maintenance" on P. 43).

CHECK : Is the entered offset value correct?

ACTION : Enter the correct value.

11. TIP STYLES

日本語

中文

English

Unit: mm (in.)

T10-B Shape-B

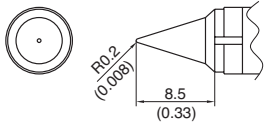

T10-B2 Shape-2B

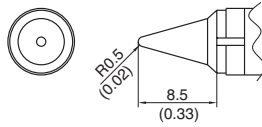

T10-BC1 Shape-1BC

T10-BCF1 Shape-1BC Cut-Surface Pre-tinned

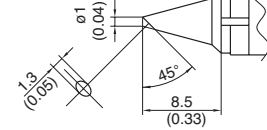

T10-BC2 Shape-2BC

T10-BCF2 Shape-2BC Cut-Surface Pre-tinned

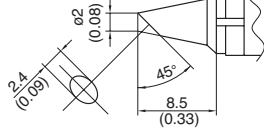

T10-BC3 Shape-3BC

T10-BCF3 Shape-3BC Cut-Surface Pre-tinned

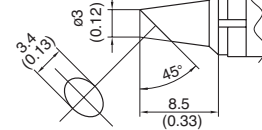

T10-BC4 Shape-4BC

T10-BCF4 Shape-4BC Cut-Surface Pre-tinned

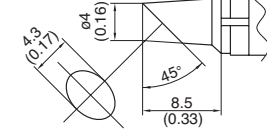

T10-C5 Shape-5C

T10-CF5 Shape-5C Cut-Surface Pre-tinned

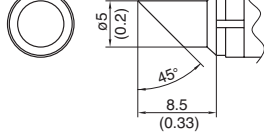

T10-C6 Shape-6C

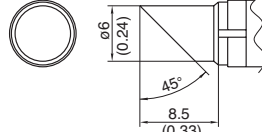

T10-D08 Shape-0.8D

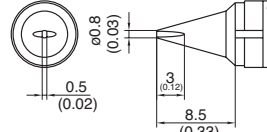

T10-D12 Shape-1.2D

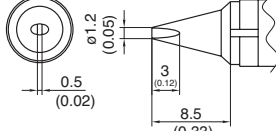

T10-D16 Shape-1.6D

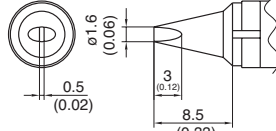

T10-D24 Shape-2.4D

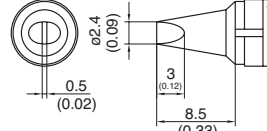

T10-D32 Shape-3.2D

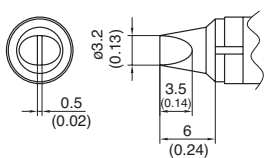

T10-D4 Shape-4D

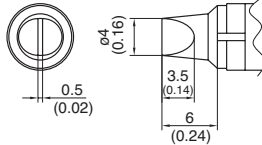

T10-D52 Shape-5.2D

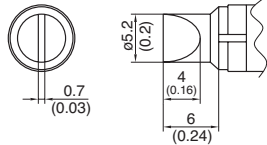

T10-D6 Shape-6D

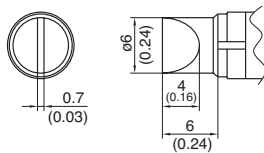

T10-I Shape-I

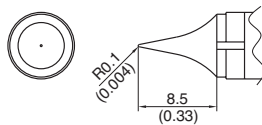

T10-J02 Shape-0.2RSB

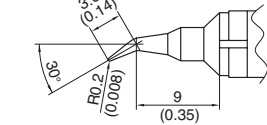

T10-K Shape-K

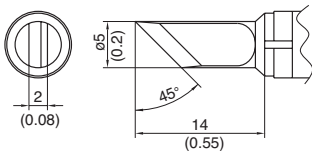

T10-KL Shape-KL

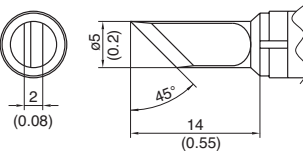

T10-KU Shape-KU

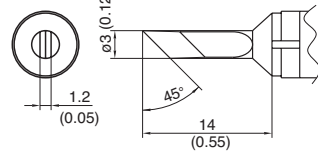

T10-LB Shape-LB

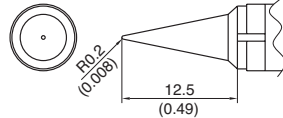

T10-LI Shape-LI

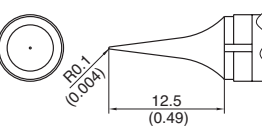

12. PARTS LIST

NOTE:

Spare or repair parts do not include mounting screws, if they are not listed on the description. Screws must be ordered separately.

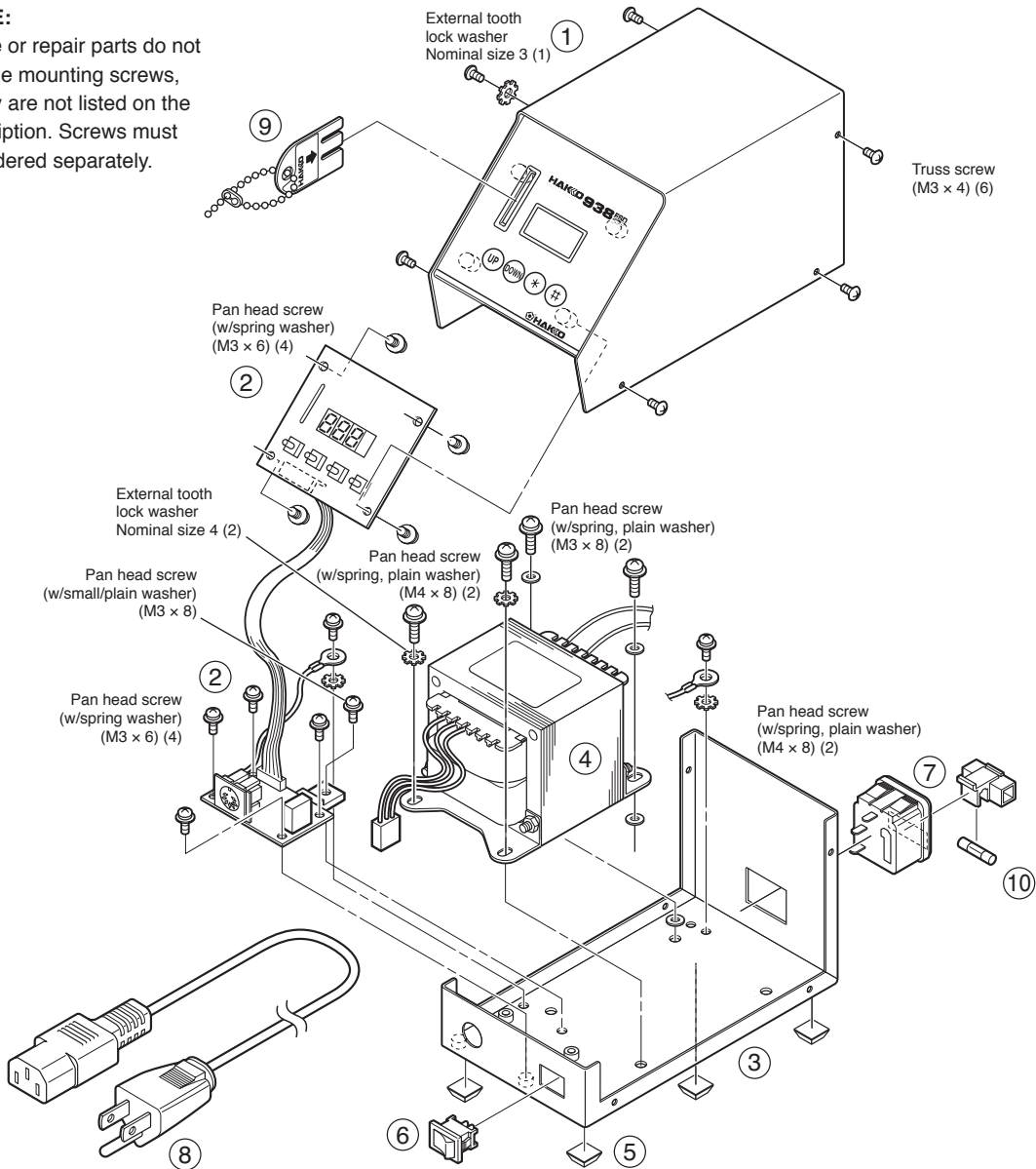

日本語
中文
English

● 938 Station

Item No.	Part No.	Part Name	Specifications
①	B2882	Cover	with membrane sheet
②	B2883	P.W.B	for temperature control & connector
③	B2884	Chassis	
④	B2885	Transformer	100V
	B2890	Transformer	110V
	B2891	Transformer	220V
	B2892	Transformer	230V
	B2903	Transformer	240V
⑤	B1037	Rubber foot	4 ea.
⑥	B1084	Power switch	
⑦	B2384	Power receptacle	

Item No.	Part No.	Part Name	Specifications
⑧	B2387	Power cord, 3 core & American plug	100V
	B2419	Power cord, 3 core & American plug	110 - 220V
	B2421	Power cord, 3 core & no plug	220 - 240V
	B2422	Power cord, 3 core & BS plug	India
	B2436	Power cord, 3 core & China plug	China
	⑨	B2388	Control cord
⑩	B2761	Fuse, 250V - 3A	100 - 110V
	B2404	Fuse, 250V - 1A	220 - 240V

12. PARTS LIST

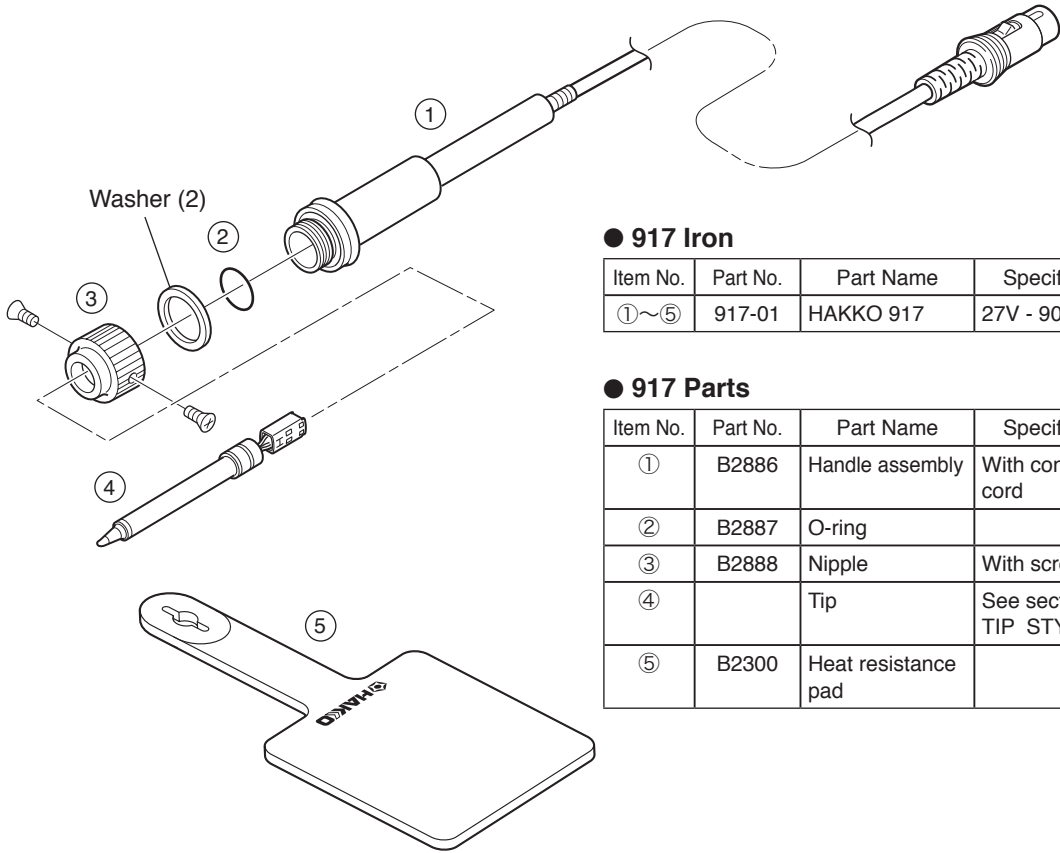

● 917 Iron

Item No.	Part No.	Part Name	Specifications
①~⑤	917-01	HAKKO 917	27V - 90W

● 917 Parts

Item No.	Part No.	Part Name	Specifications
①	B2886	Handle assembly	With connecting cord
②	B2887	O-ring	
③	B2888	Nipple	With screws
④		Tip	See section '11. TIP STYLES'.
⑤	B2300	Heat resistance pad	

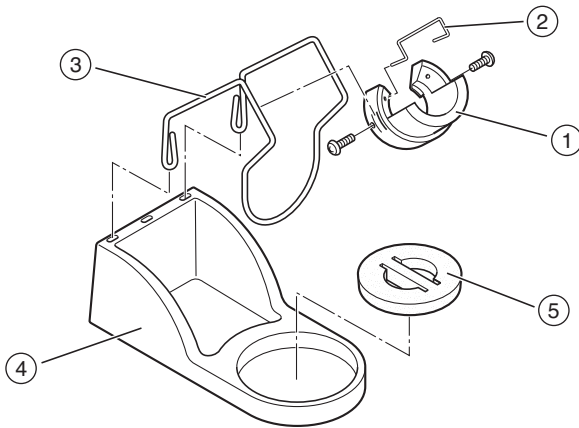

● Iron holder

Item No.	Part No.	Part Name	Specifications
①~⑤	634-05	Iron holder	

● Iron holder parts

Item No.	Part No.	Part Name	Specifications
①	B2787	Iron receptacle/ Silver	With two screws
②	B2791	Retaining clip	
③	B2786	Iron receptacle holder	
④	B2802	Iron holder base/ Gray	With rubber foot
⑤	A1495	Cleaning sponge	

13. WIRING DIAGRAM

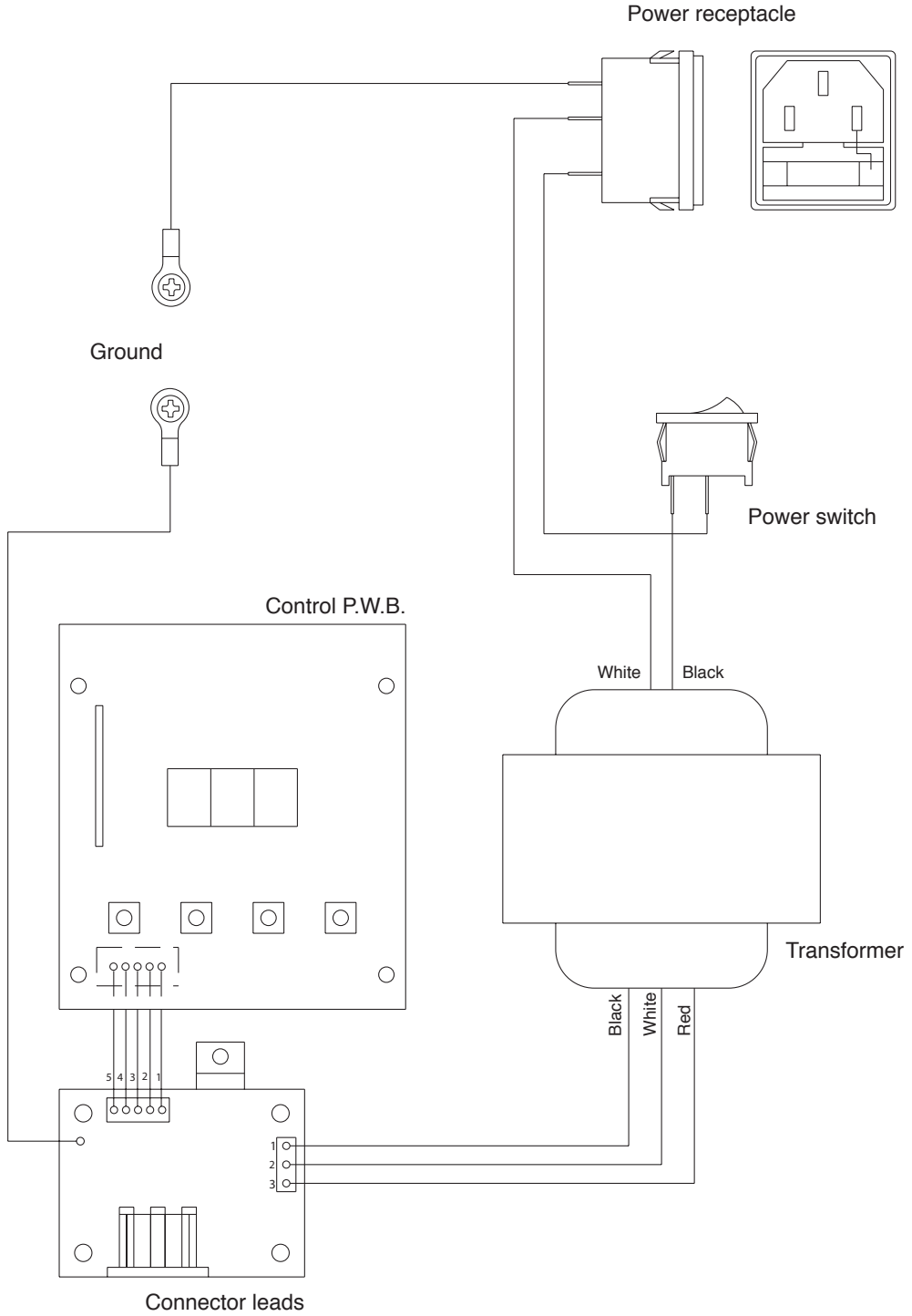



白光株式会社

<http://www.hakko.com/>

〒556-0024 大阪市浪速区塩草2丁目4番5号

TEL: (06) 6561-1574 (代) FAX: (06) 6568-0821



HAKKO CORPORATION

HEAD OFFICE

TEL: +81-6-6561-3225 FAX: +81-6-6561-8466

<http://www.hakko.com> E-mail: sales@hakko.com

OVERSEAS AFFILIATES

U.S.A.: AMERICAN HAKKO PRODUCTS, INC.

TEL: (661) 294-0090 FAX: (661) 294-0096

Toll Free (800)88-HAKKO

<http://www.hakkousa.com>

HONG KONG: HAKKO DEVELOPMENT CO., LTD.

TEL: 2811-5588 FAX: 2590-0217

<http://www.hakko.com.hk>

E-mail: info@hakko.com.hk

SINGAPORE: HAKKO PRODUCTS PTE., LTD.

TEL: 6748-2277 FAX: 6744-0033

<http://www.hakko.com.sg>

E-mail: sales@hakko.com.sg

Please access to the following address for the other Sales affiliates.

<http://www.hakko.com/address>